

Bearing Packer Pump

Overview

These pump models operate from original containers to lubricate roller and ball bearings with grease.

A cover for the bearing packer prevents contamination.

Description

The major components of the bearing packer pump assembly in the 6709 model series consist of a:

- hand-operated reciprocating pump
- bearing packer with cover and chain assembly
- cover for the container
- follower plate

Models 6709-A4 and 6709-B-4

Each bearing packer pump model is designed with a pump tube length to accommodate different size containers. See **Figure 1**.

Model 6709-B4 includes a carrying handle.

Bearing Size

Minimum and Maximum Diameters

The inside diameter of the bearing cannot be less than 19/32-inch (15.1 mm). See **Table 1**.

The maximum inside diameter the pump accommodates is 4-1/4 inches (10.8 cm). The maximum outside diameter is 8 inches (20.3 cm).

Bearing Inside Diameter				Bearing Outside Diameter	
Minimum		Maximum		Maximum	
Inch	mm	Inches	cm	Inches	cm
19/32	15.1	4-1/4	10.8	8	20.3

Table 1 Bearing Diameter Size

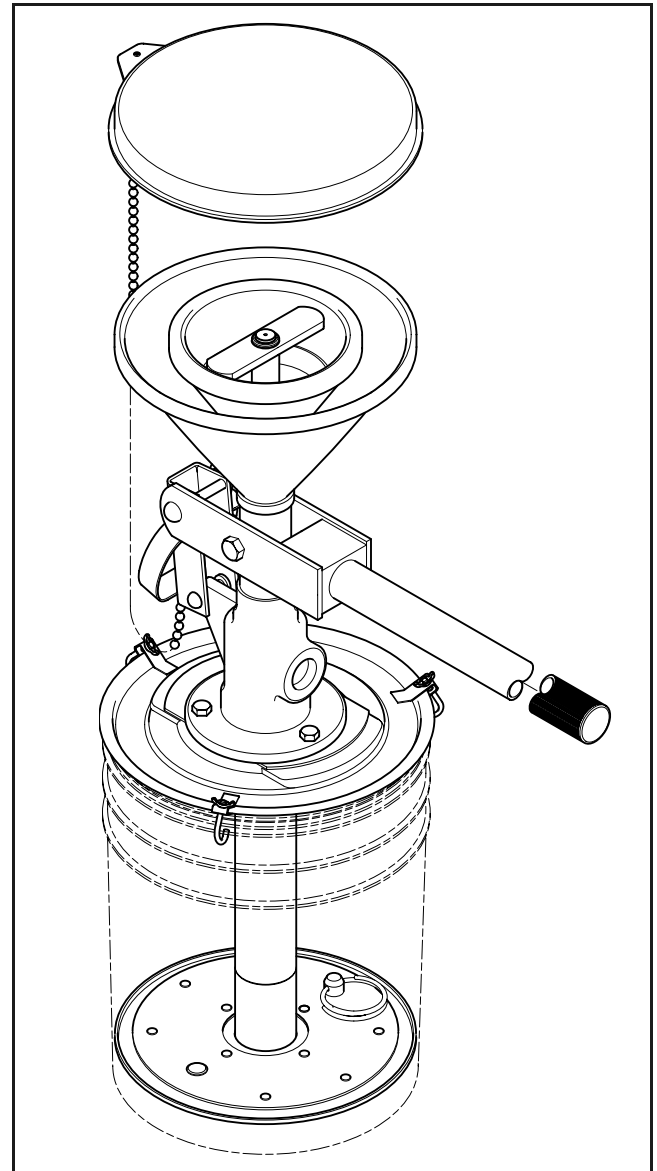

Pump Model	Container		Overall Height (including Container)	
	lbs	kg	Inches	cm
6709-A4	120	-	38	96.5
6709-B4	35	-	24	61

Figure 1 Bearing Packer Pump Model 6709 Series Model 6709-B4 Shown

Alemite Corporation
167 Rowland Drive, Johnson City, Tennessee 37601
www.alemite.com

Copyright © 2003 by Alemite Corporation

This document contains confidential information that is the property of Alemite Corporation and is not to be copied, used, or disclosed to others without express written permission.

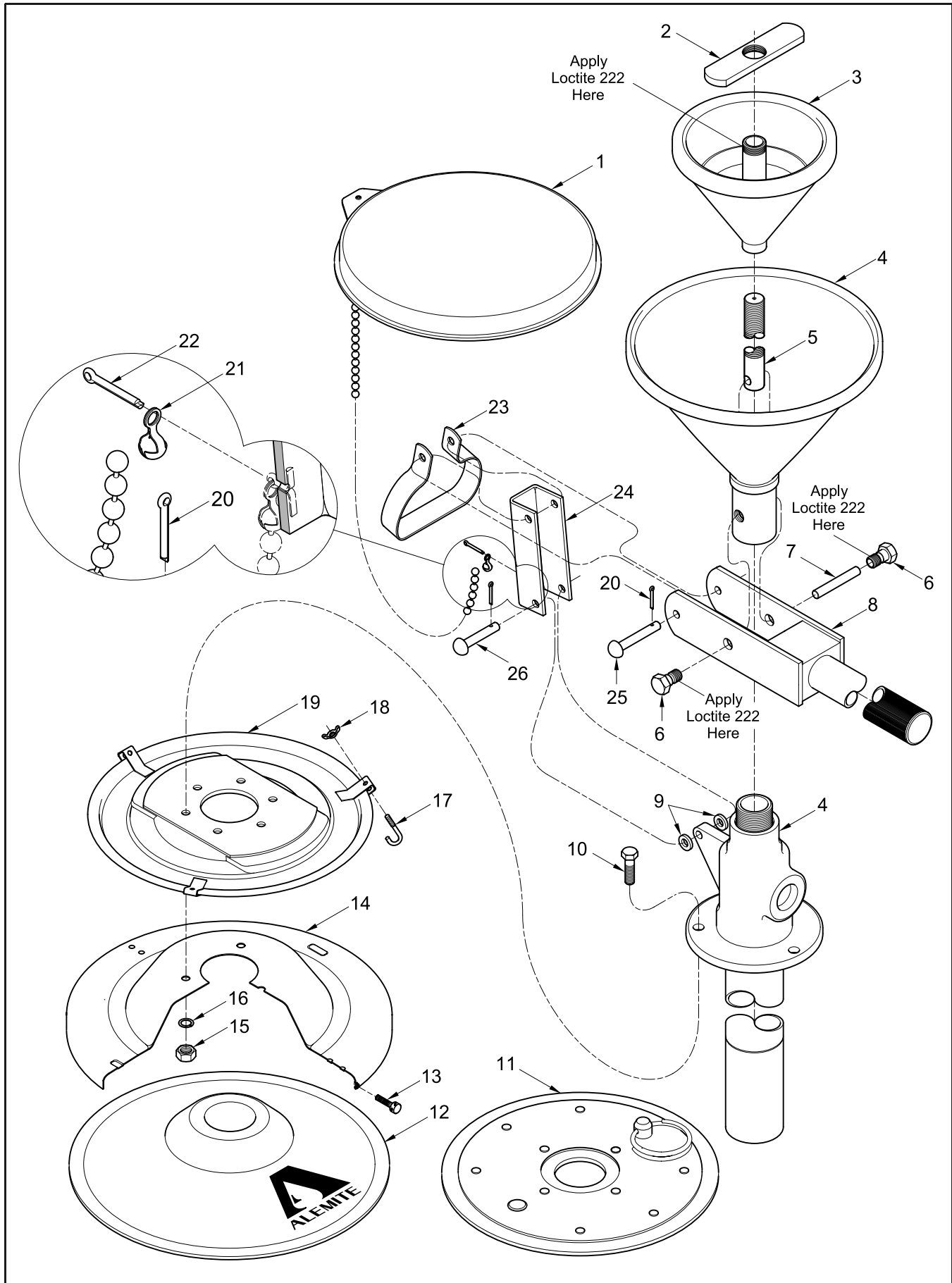

Figure 2-A Bearing Packer Pump Model 6709 Series - Exploded View

Item No.	Part No.	Description	Qty	Model		Notes	Numeric Order Part # (Item #)
				6709-A4	6709-B4		
1	333316	Cover and Chain Assembly	1				43651 (20)
2	332404	Handle	1				48018 (13)
3	332389	Cone Assembly, Inner	1				76771 (10)
4		Pump Assembly	1			See Figure 2-B	77650 (15)
		Pump Assembly	1				170837 (18)
5	332406	Stud	1				172207-2 (16)
6	336497	Bearing, Sleeve	2				172212-19 (22)
7	332968	Pin, Pivot	1				317102 (17)
8		Lever Assembly	1				318414 (23)
9		Washer, 0.26 "	2				328245-4 (14)
10		Screw, 1/4 " -20 x 3/4 "	3				330790 (21)
11	338825	Plate Assembly, Follower	1				332389 (3)
12	338803	Plate Assembly, Follower	1				332392 (8)
13	48018	Screw, Thumb	3				332400-B4 (4)
14	328245-4	Cover Assembly	1				332400-C4 (4)
15	77650	Nut, 1/4 " -20	3				332404 (2)
16		Washer, Lock, 5/16 "	3				332406 (5)
17	317102	J-Bolt, 1/4 " -20	3				332407 (24)
18	170837	Nut, Wing, 1/4 " -20	3				332409 (25)
19	337729	Cover Assembly	1				332410 (26)
20	43651	Pin, Cotter, 1/16 " x 1/2 " Long	2				332421 (9)
21		Coupling (Brass)	1				332968 (7)
22		Pin, Cotter, 3/32 " x 1/2 " Long	1				333316 (1)
23	318414	Handle	1				336497 (6)
24		Link	1				337729 (19)
25	332409	Pin, 1-9/16 " Long	1				338803 (12)
26	332410	Pin, 1 " Long	1				338825 (11)
<p>Legend: Part numbers left blank (or in <i>italics</i>) are not available separately</p>							

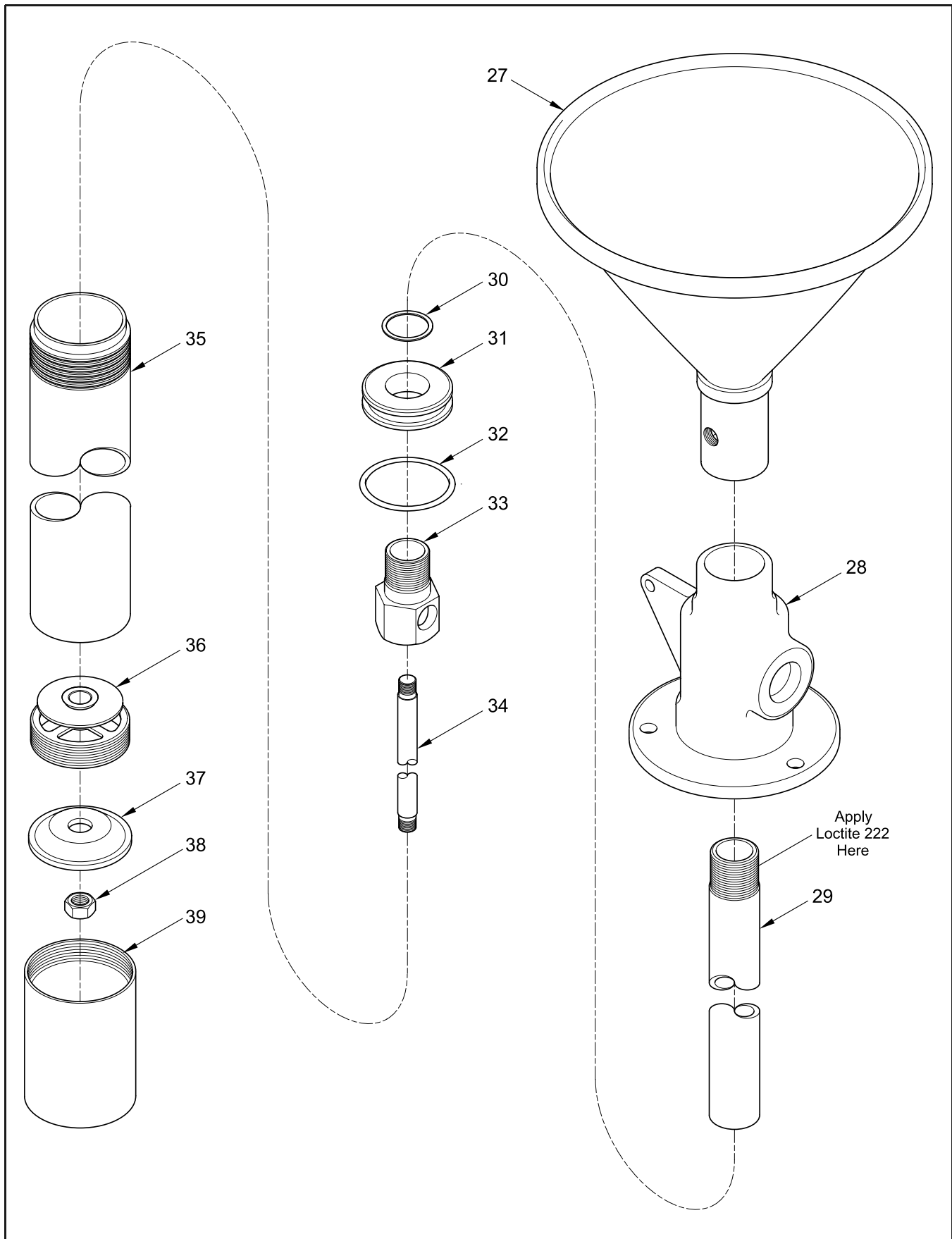

Figure 2-B Bearing Packer Pump Model 6709 Series - Exploded View

Item No.	Part No.	Description	Qty	Model		Numeric Order Part # (Item #)
				6709-A4	6709-B4	
27	332386	Cone Assembly, Outer	1			18850 (38)
28		Head, Pump	1			171000-23 (32)
29	332396-3	Extension, Piston, 25-1/2 " Long	1			306121 (30)
	332396-2	Extension, Piston, 10-5/8 " Long	1			317238 (36)
30	306121	Gasket (Aluminum)	1			<i>317243</i> (39)
31		Piston	1			317244 (37)
32	171000-23	O-Ring, 1-1/4 " ID x 1-1/2 " OD	1			332386 (27)
33		Connector, Rod	1			332396-2 (29)
34		Rod	1			332396-3 (29)
35	332397-3	Cylinder, 24-5/8 " Long	1			332397-2 (35)
	332397-2	Cylinder, 9.66 " Long	1			332397-3 (35)
36	317238	Valve Assembly, Foot	1			<i>332398-1</i> (28)
37	317244	Disc, Primer	1			<i>332399</i> (33)
38	18850	Nut, Elastic Stop, 1/4 " -28	1			<i>332401</i> (31)
39		Tube	1			<i>332402</i> (34)
Legend: Part numbers left blank (or in <i>italics</i>) are not available separately						

Overhaul

WARNING

Read each step of the instructions carefully. Make sure a proper understanding is achieved before proceeding.

NOTE: These procedures are applicable to the pump tube only.

Disassembly

NOTE: Refer to **Figures 2-A** and **2-B** for component identification on the following procedures.

1. Position Lever Assembly (8) fully downward.
 - This allows Primer Disc (37) to protrude from Tube (39).
2. Remove Elastic Stop Nut (38) from Rod (34).

NOTE: The Rod may unscrew from Rod Connector (33).
3. Remove Primer Disc (37) from the Rod.
4. Unscrew and remove Cylinder (35) [with attached components] from Pump Head (28).
5. Unscrew Tube (39) [or the Cylinder] from Foot Valve Assembly (36).
6. Unscrew the Foot Valve Assembly from the remaining component.
7. Remove O-Ring (32) from Piston (31).
8. Unscrew Rod (34) from Rod Connector (33) as required.
9. Unscrew the Rod Connector from Piston Extension (29).
10. Remove Gasket (30) and the Piston from the Rod Connector.

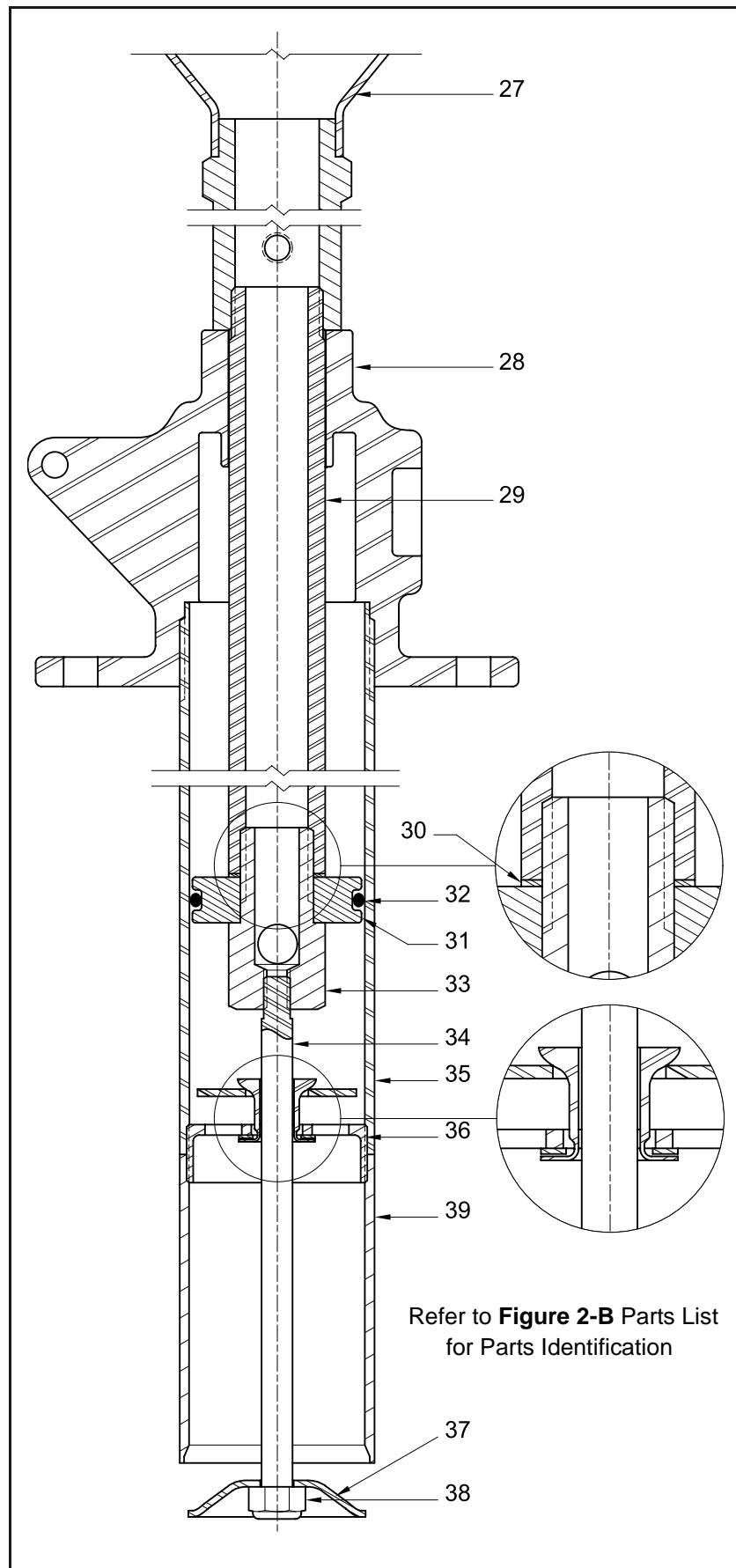

Figure 3 Pump Assembly - Section View

Clean and Inspect

1. Clean all metal parts in a modified petroleum-based solvent. The solvent should be environmentally safe.
2. Inspect all parts for wear and/or damage.
 - Replace as necessary.
3. Closely inspect the mating surfaces of Foot Valve Assembly (36) for any imperfections. Ensure a smooth and clean contact is obtained.

Assembly

NOTE: Prior to assembly, lubricate O-Ring (32) in clean oil.

1. Install and seat Piston (31) and Gasket (30) onto Rod Connector (33).
2. Screw the Rod Connector assembly into Piston Extension (29).
 - Tighten the Rod Connector securely.
3. Install O-Ring (32) onto the Piston.
4. Screw Rod (34) into the Rod Connector.
 - Do not tighten at this time.
5. Screw Cylinder (35) into Pump Head (28).
 - Use care no to damage the O-Ring.
 - Do not tighten at this time.
6. Install Foot Valve Assembly (36) [washer end first] onto the Rod and screw into the Cylinder.
 - Do not tighten at this time.
7. Screw Tube (39) onto the Foot Valve Assembly.
8. Tighten the Tube and Cylinder assembly securely to the Foot Valve Assembly and to the Pump Head.
9. Install Primer Disc (37) [small diameter first] onto the Rod.
10. Screw Elastic Stop Nut (38) onto the Rod.
 - Tighten the Nut securely and at the same time secure the Rod to the Rod Connector.

Operation

NOTE: Refer to **Figures 2-A** and **2-B** for component identification on the operational procedures.

1. Wash the used grease from the wheel bearing in cleaning solvent.

CAUTION

Do not allow the bearing to spin. Damage can occur.

2. Dry the bearing thoroughly with compressed air.
3. Remove Cover (1) from Outer Cone Assembly (27).
4. Unscrew Inner Cone (3) from Stud (5).
5. Position the wheel bearing (wide side downward if bearing is tapered) over the Stud and into the Outer Cone Assembly.
 - Make sure the bearing is centered within the Outer Cone.
6. Screw the Inner Cone onto the Stud.
 - Make sure the Inner Cone contacts the bearing squarely and securely.
7. Operate the Lever of the pump.
 - Visually inspect the entire bearing surface for clean lubricant.
8. Unscrew the Inner Cone from the Stud and remove the bearing.
9. Screw the Inner Cone onto the Stud and replace the Cover.

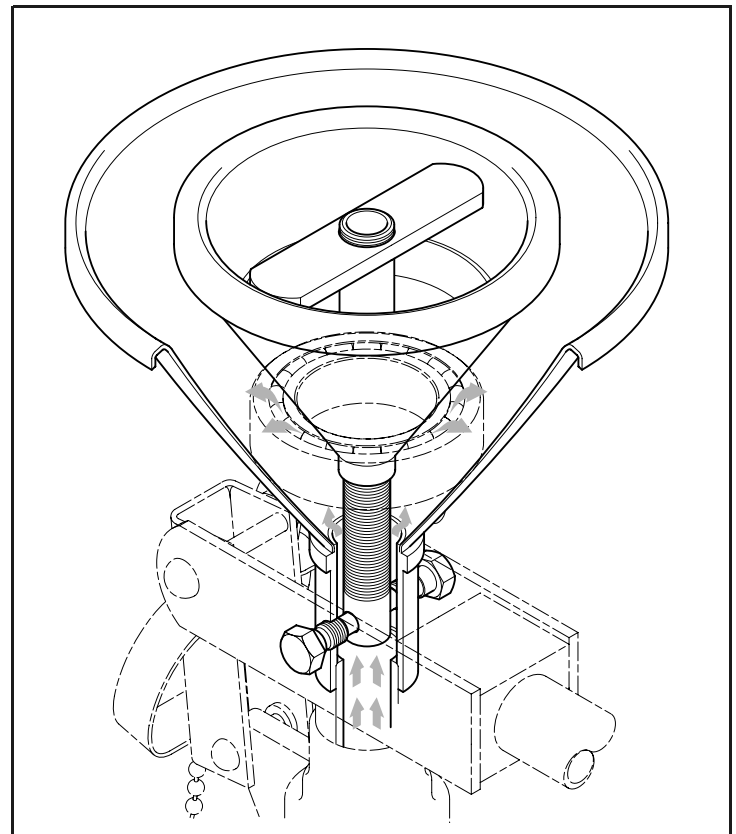

Figure 4 Bearing Installed within Pump's Cone Assemblies

Troubleshooting Chart

Pump Indications	Possible Problems	Solution
Pump does not cycle	Pump tube jammed and/or contains loose components	Rebuild pump tube
Pump will not prime	Pump leaking internally	See Internal Leaks
Pump cycles easily	Product source empty	Replenish product
External Leaks		
Product leakage at top of Pump Head (28)	Worn or damaged O-Ring (32)	Replace O-Ring (32)
Internal Leaks		
Pump does not prime	<ol style="list-style-type: none"> 1. Foreign material between components of Foot Valve Assembly (36) 2. Missing Primer Disc (37) 	Locate and eliminate source of foreign material Replace missing component(s)

Changes Since Last Printing

Changed Part Number 330790