

## Low-Pressure Stub Pump

### Description

The major components of the 7202 stub pump consist of an air-operated motor and a pump tube. The air motor connects directly to the double-acting reciprocating pump tube.

This low-pressure stub pump is designed to deliver a range of light weight oils including gear lubricants. The pump's bung adapter [2" NPTF (m)] allows installation directly onto original containers or bulk tanks.

As an alternative, the pump can also mount to a wall. See **Table 2**.

The stub pump accepts a variety of different length and types of extension tubes. These extension tubes should be equipped with a low level cut-off valve.

### CAUTION

**A lubricator must be used with this pump to comply with the Warranty. The minimum rate is 1 drop per minute and must not exceed 2 drops per minute.**

### Specifications

#### Air Motor

Piston Diameter / Stroke		Air Inlet	Min. Air Pressure		Max. Air Pressure	
Inches	Millimeters		psi	Bars	psi	Bars
2 / 3	51 / 76	1/4" NPTF (f)	44	3	125	8.6

#### Pump Tube

Ratio	Max. Material Pressure		Material Inlet	Material Outlet	Delivery/Minute (Approximate)*	
	psi	Bars			Gallons	Liters
1:1	125	8.6	1" NPTF (f)	3/4" NPTF (f)	10.6	40

\* For detailed information, refer to **Figure 3**

**Table 1** Low-Pressure Stub Pump Model 7202 Specifications

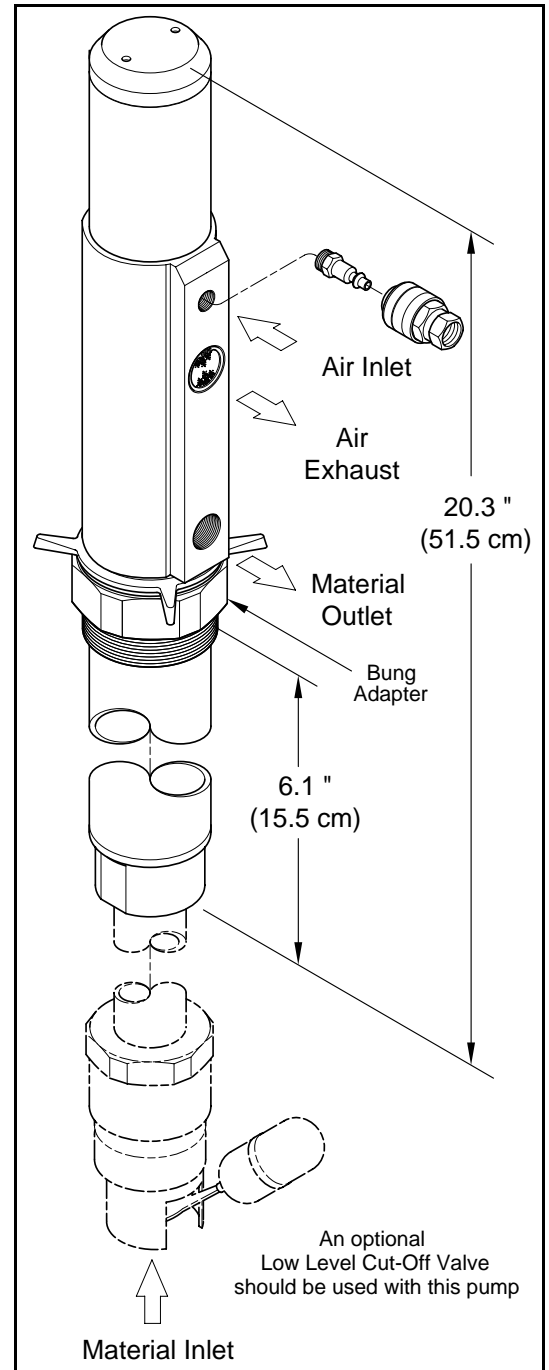

**Figure 1** Low-Pressure Stub Pump

Alemite Corporation  
 PO Box 473515, Charlotte, North Carolina 28247-3515

Copyright © 1996 by Alemite Corporation

This document contains confidential information that is the property of Alemite Corporation and is not to be copied, used, or disclosed to others without express written permission.

SER 7202  
 Revision (5-96)

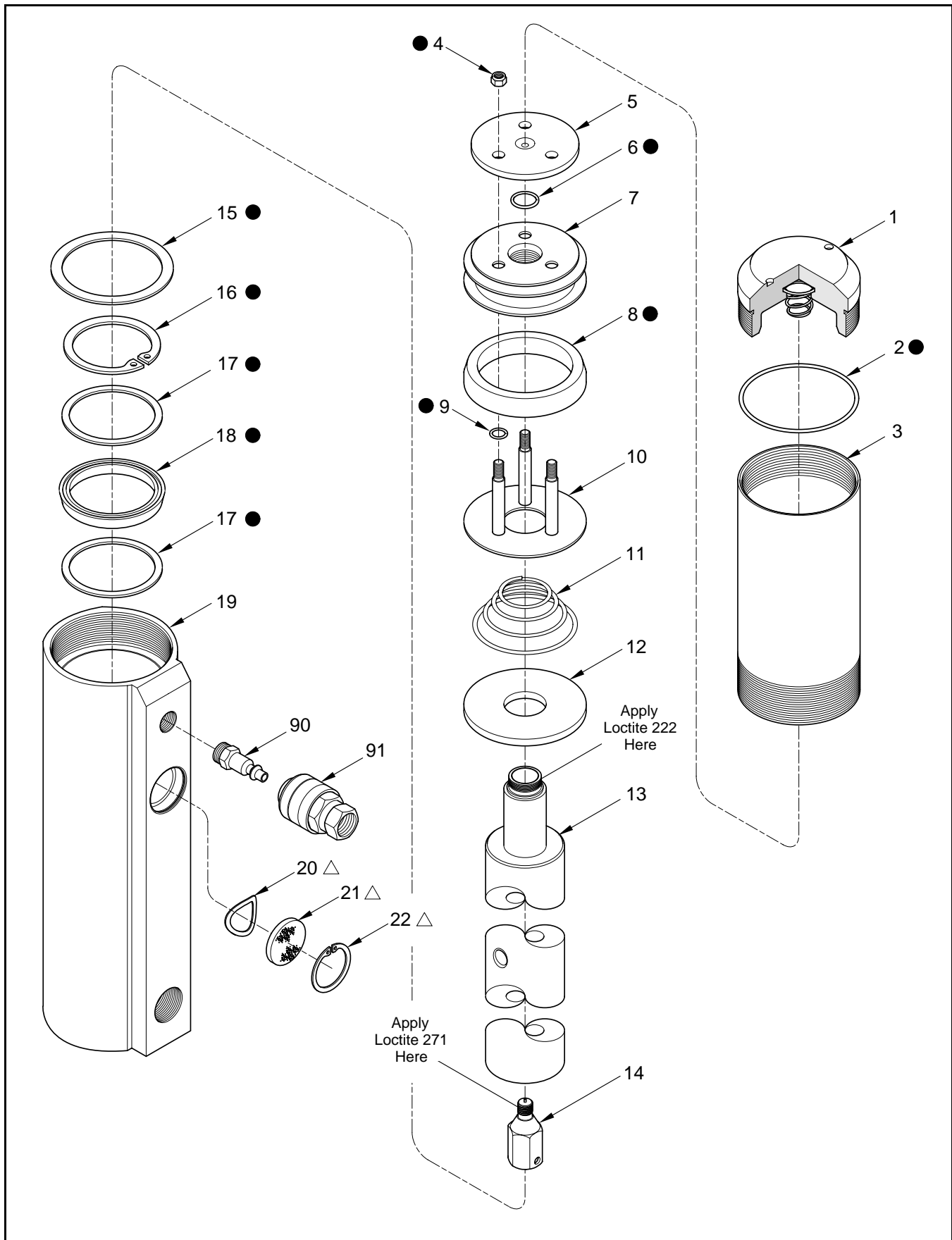

Figure 2-A Low-Pressure Stub Pump Model 7202 - Exploded View

Item No.	Part No.	Description	Qty	Notes	Numeric Order Part # (Item #)
1	393665-1	Head and Spring Assembly	1		328030 (91)
2		O-Ring (Buna-N)	2	● □ *	328034 (90)
3	393665-3	Cylinder, Air	1		393665-1 (1)
4		Locknut, 7 mm	3	●	<i>393665-2</i> (2)
5	393665-5	Plate, Seal	1		393665-3 (3)
6		O-Ring (Buna-N)	1	●	<i>393665-4</i> (4)
7	393665-7	Piston, Air	1		393665-5 (5)
8		V-Packing (Buna-N)	1	●	<i>393665-6</i> (6)
9		O-Ring (Buna-N)	3	●	393665-7 (7)
10	393665-10	Stop, Air Valve	1		<i>393665-8</i> (8)
11	393665-11	Spring, Conical, Heavy	1		<i>393665-9</i> (9)
12	393665-12	Washer, Stop	1		393665-10 (10)
13	393665-13	Piston	1		393665-11 (11)
14	393665-14	Coupling	1		393665-12 (12)
15		Seal, Air Cylinder (PVC)	1	●	393665-13 (13)
16		Circlip, Internal	2	● □ *	393665-14 (14)
17		Holder, Packing	2	● *	<i>393665-15</i> (15)
18		V-Packing (Buna-N)	1	●	<i>393665-16</i> (16)
19		Body, Casting	1		<i>393665-17</i> (17)
20		Washer, Wave	1	△	<i>393665-18</i> (18)
21		Muffler	1	△	<i>393665-19</i> (19)
22		Circlip, Internal	1	△	<i>393665-20</i> (20)
90	328034	Connector, 1/4 " NPTF (m)	1		<i>393665-21</i> (21)
91	328030	Coupler, Air, 1/4 " NPTF (f)	1		<i>393665-22</i> (22)

**Legend:**

Part numbers left blank (or in *italics*) are not available separately

● △ □ designates a repair kit item

\* Quantity of one (1) in designated kit

**Repair Kits**

Part No.	Kit Symbol	Description	Notes
<b>393665-101</b>	●	Kit, Air Motor Repair	Includes Items on <b>Figure 2-A</b> and <b>2-B</b>
<b>393665-102</b>	△	Kit, Muffler Repair	
<b>393665-103</b>	□	Kit, Pump Tube Repair	Includes Items on <b>Figure 2-A</b> and <b>2-B</b>

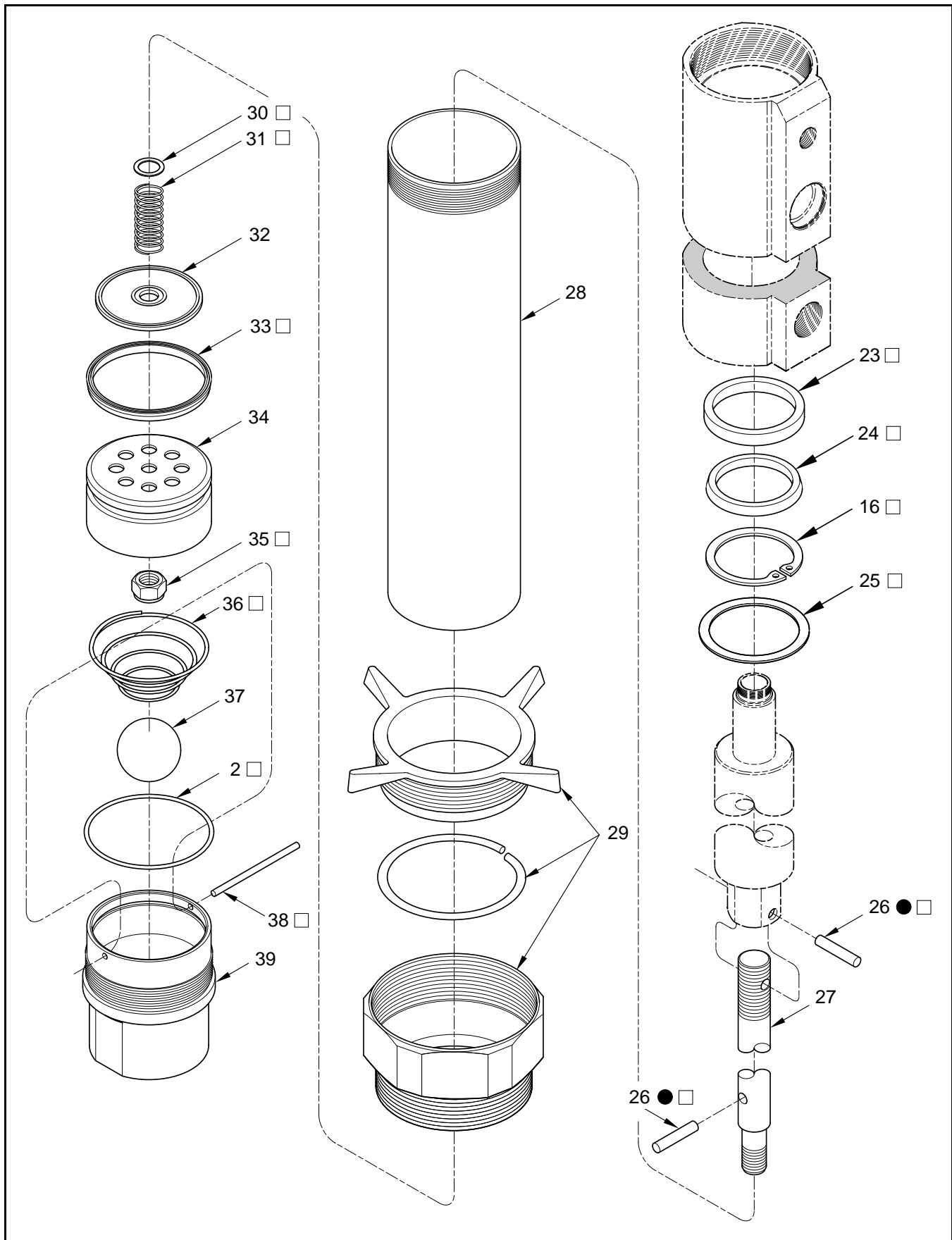

Figure 2-B Low-Pressure Stub Pump Model 7202 - Exploded View

Item No.	Part No.	Description	Qty	Notes	Numeric Order Part # (Item #)
23		Sleeve, Guide	1	<input type="checkbox"/>	393665-23 (23)
24		V-Packing (Polyurethane)	1	<input type="checkbox"/>	393665-24 (24)
25		Seal, Pump Tube (Polyethylene)	1	<input type="checkbox"/>	393665-25 (25)
26		Pin, Roll, 3 x 18 mm	2	● <input type="checkbox"/>	393665-26 (26)
27	393665-27	Rod	1		393665-27 (27)
28	393665-28	Cylinder, Fluid	1		393665-28 (28)
29	393665-29	Adapter Assembly, Bung	1		393665-29 (29)
30		Stop, Spring	1	<input type="checkbox"/>	393665-30 (30)
31		Spring	1	<input type="checkbox"/>	393665-31 (31)
32	393665-32	Valve, Flat Check	1		393665-32 (32)
33		V-Packing (Buna-N)	1	<input type="checkbox"/>	393665-33 (33)
34	393665-34	Piston, Fluid	1		393665-34 (34)
35		Locknut, 13 mm	1	<input type="checkbox"/>	393665-35 (35)
36		Spring, Conical, Light	1	<input type="checkbox"/>	393665-36 (36)
37	393665-37	Ball, 22 mm	1		393665-37 (37)
38		Pin, Roll, 3 x 45 mm	1	<input type="checkbox"/>	393665-38 (38)
39	393665-39	Adapter, Inlet	1		393665-39 (39)
<b>Legend:</b> ● <input type="checkbox"/> designates a repair kit item					

**Repair Kits**

Part No.	Kit Symbol	Description	Notes
393665-101	●	Kit, Air Motor Repair	Includes Items on <b>Figure 2-B</b> and <b>2-A</b>
393665-103	<input type="checkbox"/>	Kit, Pump Tube Repair	

## Accessories

This model pump can be used in a variety of locations which allows an assortment of accessory items to be utilized. Please refer to the Sales Catalog for details on additional accessory items.

Low Level Cut-Off Valve	Siphon Kit	Wall Bracket
321206	SWA 306	325749

**Table 2** Model 7202 Accessory Components

## Preventive Maintenance

Refer to section entitled **Overhaul** for the procedures necessary to perform maintenance.

Daily	Weekly	Monthly	Yearly
Wipe Exterior with Clean Cloth	Inspect for Air and/or Fluid Leakage	Inspect Muffler	

**Table 3** Model 7202 Preventive Maintenance Schedule

## Performance Chart

A pump's ability to deliver material is based on the pressure (psi/Bars) and quantity (cfm/lpm) of air supplied to the motor and the amount of material discharge [back] pressure to be overcome within the system.

This chart contains curves based on three different air pressures. The curves relate delivery in gallons (liters) per minute (X axis) to air consumption in cubic feet (liters) per minute (right Y axis) and to material discharge pressure in psi/Bars (left Y axis).

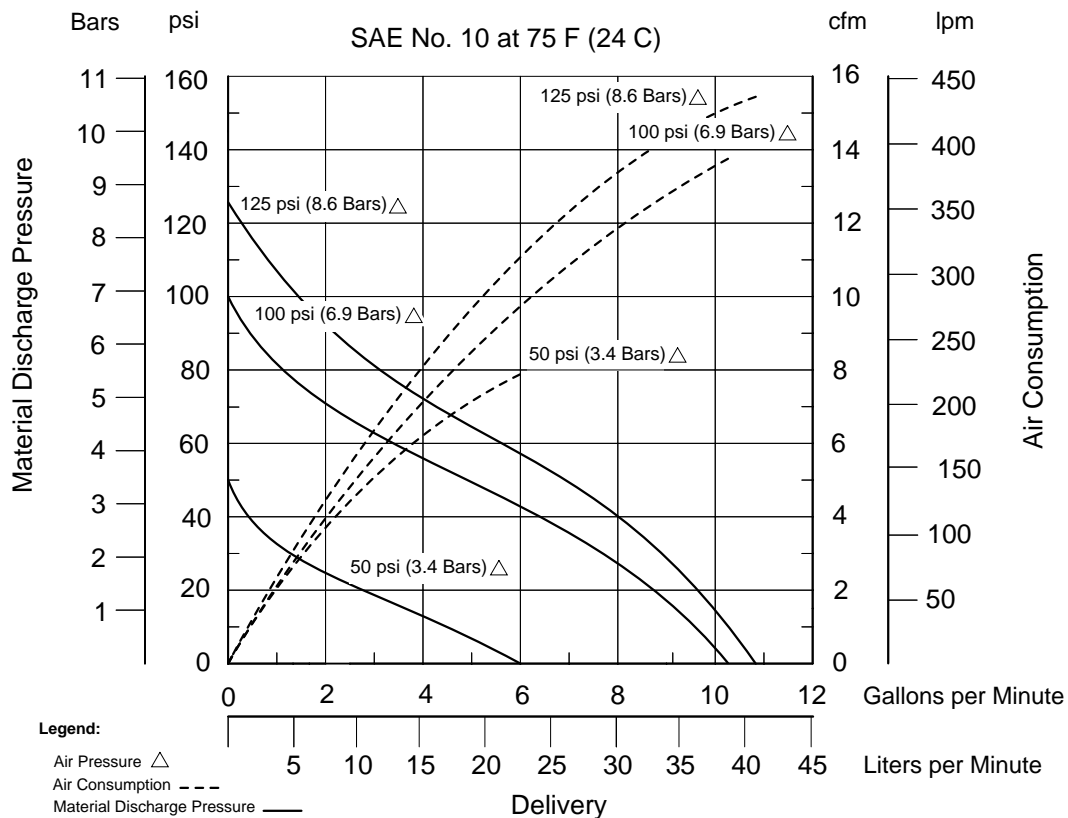

**Figure 3** Delivery versus Discharge Pressure and Air Consumption

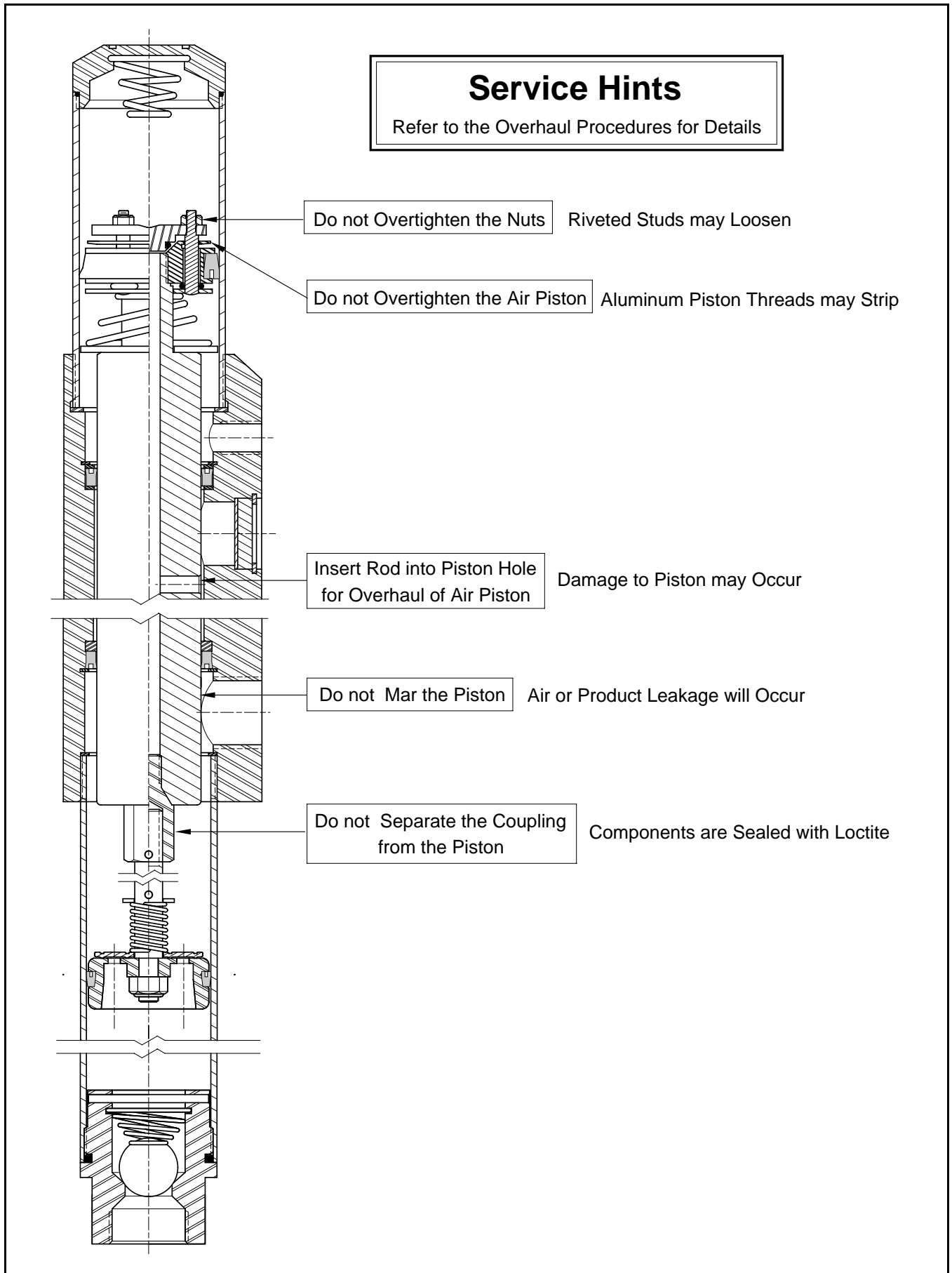

*IMPORTANT: Prior to performing any maintenance procedure, the following safety precautions must be observed. Personal injury may occur.*



## WARNING

Do not use halogenated hydrocarbon solvents such as methylene chloride or 1,1,1-trichloroethane in this pump. An explosion can result in pumps when aluminum and/or zinc-plated parts come in contact with halogenated hydrocarbon solvents.

Release all pressure within the system prior to performing any overhaul procedure.

- Disconnect the air supply line from the pump motor.
- Into an appropriate container, operate the control valve to discharge remaining pressure within the system.

Never point a control valve at any portion of your body or another person. Accidental discharge of pressure and/or material can result in injury.

Read each step of the instructions carefully. Make sure a proper understanding is achieved before proceeding.

## Overhaul

**NOTE:** Refer to **Figures 2-A** and **2-B** for component identification on all overhaul procedures.

### Disassembly

#### Separate Pump Tube from Air Motor

1. Place the pump assembly in a soft-jaw vise. See **Figure 4**.
2. Unscrew the Cylinder assembly from the air motor.
  - Use Bung Adapter (**29**) for leverage.
3. Remove the Cylinder assembly from the Rod assembly.

## CAUTION

Support the Coupling and Rod during Roll Pin removal. Damage to components can occur.

4. Remove Roll Pin (**26**) that secures the Rod to Coupling (**14**).
  - Use an appropriate size punch and a small hammer.
5. Unscrew the Rod assembly from the Coupling.

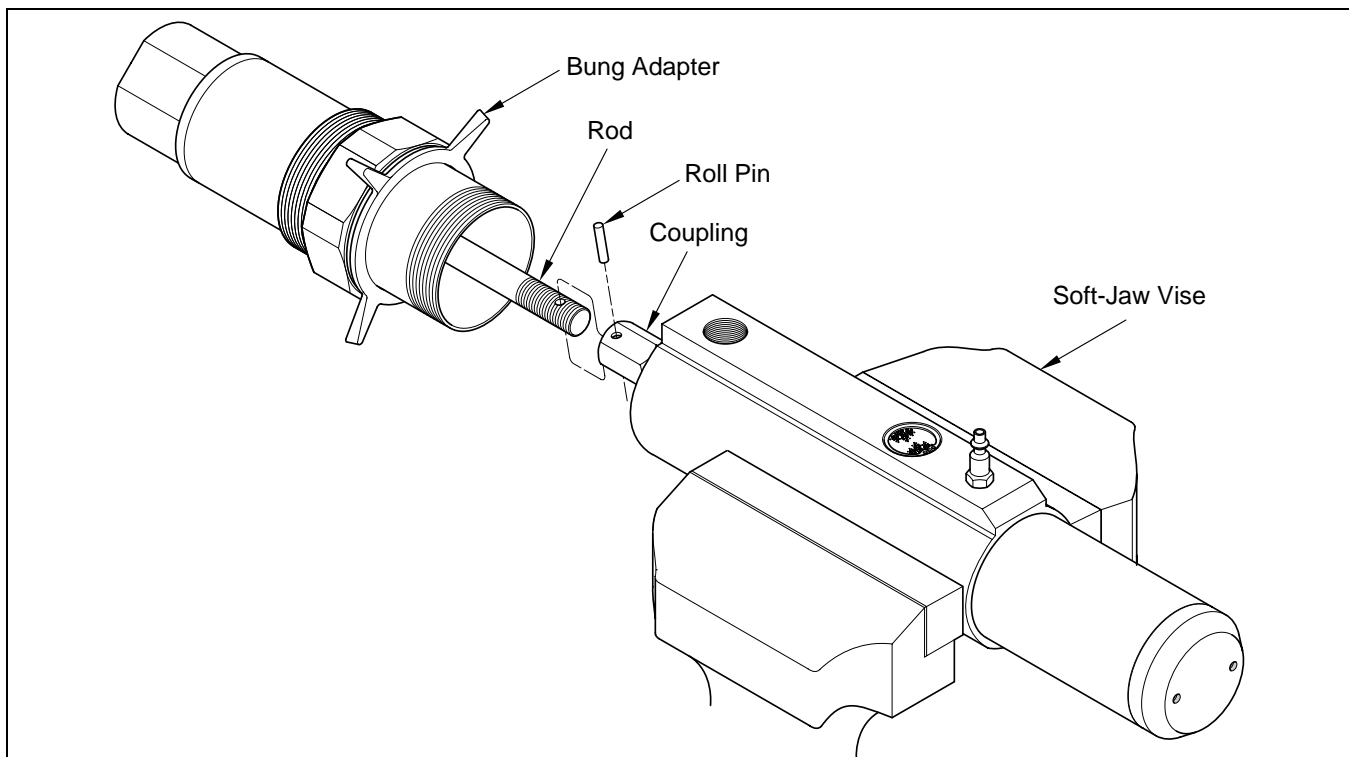

**Figure 4** Separation of Pump Tube Assembly from Air Motor

### Pump Tube

6. Remove Locknut (35) that secures the Rod to Fluid Piston (34).
  - Remove the Fluid Piston from the Rod.
7. Remove Flat Check Valve (32), Spring (31), and Spring Stop (30) from the Rod.
8. Remove V-Packing (33) from the Fluid Piston.
9. Remove Bung Adapter (29) from Fluid Cylinder (28).
10. Unscrew Inlet Adapter (39) from the Fluid Cylinder.
  - Use a strap wrench.
11. Remove Roll Pin (38) from the Inlet Adapter.
  - Use an appropriate size punch and a small hammer.
12. Remove Conical Spring (36), Ball (37), and O-Ring (2) from the Inlet Adapter.

### Air Motor

13. Place the motor in a soft-jaw vise.
14. Unscrew Air Cylinder (3) from Casting Body (19).
  - Use a strap wrench.
15. Remove the entire Piston assembly from the top of the Casting Body.

### Air Piston

*IMPORTANT: Disassemble the Air Piston assembly only when internal components require replacement or leakage occurs. Certain components are sealed with Loctite.*

*Do not grip the surface of Piston (13) with any tool that will mar its surface. Air leakage will occur.*

16. Remove Nuts (4) that secure Seal Plate (5) to Air Valve Stop (10).
  - Remove the Seal Plate.
17. Remove O-Ring (6) from the Seal Plate.
18. Remove V-Packing (8) from Air Piston (7).
 

*IMPORTANT: Do not mar the sealing surfaces of Air Piston (7) during removal. Air leakage will occur.*
19. Unscrew Air Piston (7) from Piston (13).
  - Grip the upper portion of the Air Piston with vice-grips and place an appropriate size rod into the hole of the Piston.

20. Remove O-Rings (9) from the Air Valve Stop.
21. Remove the Air Valve Stop, Conical Spring (11), and Stop Washer (12) from Piston (13).

*IMPORTANT: Do not separate Coupling (14) from the Piston unless it has been determined that product is chasing the threads. Components are sealed with Loctite.*

### Casting Body

22. Remove Air Cylinder Seal (15) from the Casting Body.
23. Remove Internal Circlip (16) from the air side of the Casting Body.
24. Remove Packing Holder (17), V-Packing (18), and the additional Packing Holder from the Casting Body.
25. Remove Pump Tube Seal (25) from the Casting Body.
26. Remove Internal Circlip (16) from the fluid side of the Casting Body.
27. Remove V-Packing (24) and Guide Sleeve (23) from the Casting Body.
28. Remove Circlip (22), Muffler (21) and Wave Washer (20) from the Casting Body.

### Head Assembly

29. Unscrew Head and Spring Assembly (1) from the Air Cylinder as required.
  - Use a spanner wrench.
30. Remove O-Ring (2) from the Head Assembly.

### Clean and Inspect

**NOTE:** Use the appropriate repair kit for replacement parts. Make sure all the components are included in the kit before discarding used parts.

1. Clean all metal parts in a modified petroleum-based solvent. The solvent should be environmentally safe.
  - Make sure to remove the old sealant from the threads of all components.
2. Inspect all parts for wear and/or damage.
  - Replace as necessary.
3. Inspect Piston (13) closely.
  - Replace as necessary.

4. Closely inspect the mating surfaces of all components for any imperfections. Ensure that a smooth and clean contact is obtained when assembled.

**EXAMPLE:** Place Ball (37) into Inlet Adapter (39). Fill the Inlet Adapter with solvent. Make sure no leakage occurs.

### Assembly

**NOTE:** Prior to assembly, certain components require lubrication in clean oil. Refer to Table 4 for details.

#### Pump Tube

**NOTE:** Refer to **Figure 5** and **Figure 2-B** for component identification on pump tube assembly procedures.

1. Install Ball (37), and Conical Spring (36) [large diameter upward] into the Inlet Adapter.
  - Make sure the Spring seats properly in the groove.
2. Install Roll Pin (38) into the Inlet Adapter.
  - Use a small hammer.
  - Make sure the Pin is flush with both sides of the Adapter.
3. Install V-Packing (33) [lips upward] onto the top of Fluid Piston (34) [surface with holes].
4. Install Spring Stop (30), Spring (31), Flat Check Valve (32) [flat side upward], and the Fluid Piston assembly onto the bottom of the Rod.
5. Install Locknut (35) that secures the Fluid Piston assembly to the Rod.
  - Tighten the Locknut securely.
6. Install the Fluid Piston and Rod assembly into the top of Fluid Cylinder (28).
  - Use care when passing over the V-Packing.
7. Install O-Ring (2) onto Inlet Adapter (39).
8. Screw the Inlet Adapter assembly into the Fluid Cylinder.
  - Use care when passing over the O-Ring.
  - Do not tighten at this time.

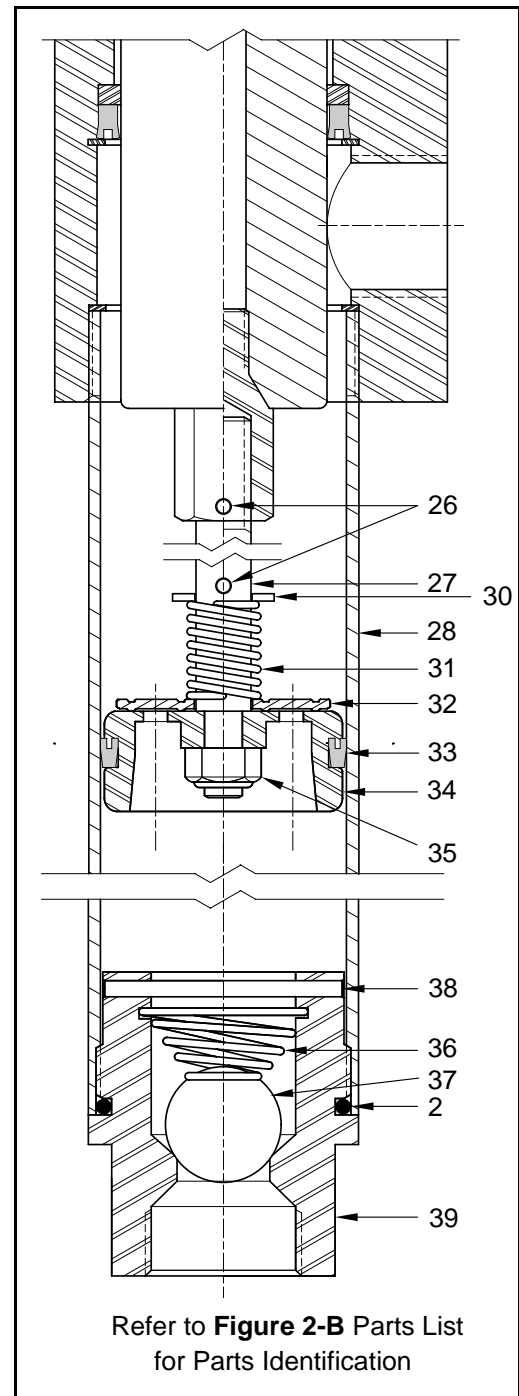

**Figure 5** Pump Tube Assembly  
Section View

Item No. on Figures 2-A and 2-B	Description	Item No. on Figures 2-A and 2-B	Description
2	O-Ring (Buna-N)	18	O-Ring (Buna-N)
6	O-Ring (Buna-N)	24	O-Ring (Polyurethane)
8	V-Packing (Buna-N)	25	Seal, Pump Tube (Polyethylene)
9	O-Ring (Buna-N)	33	V-Packing (Buna-N)
15	Seal, Air Cylinder (PVC)		

**Table 4** Components that Require Lubrication in Clean Oil

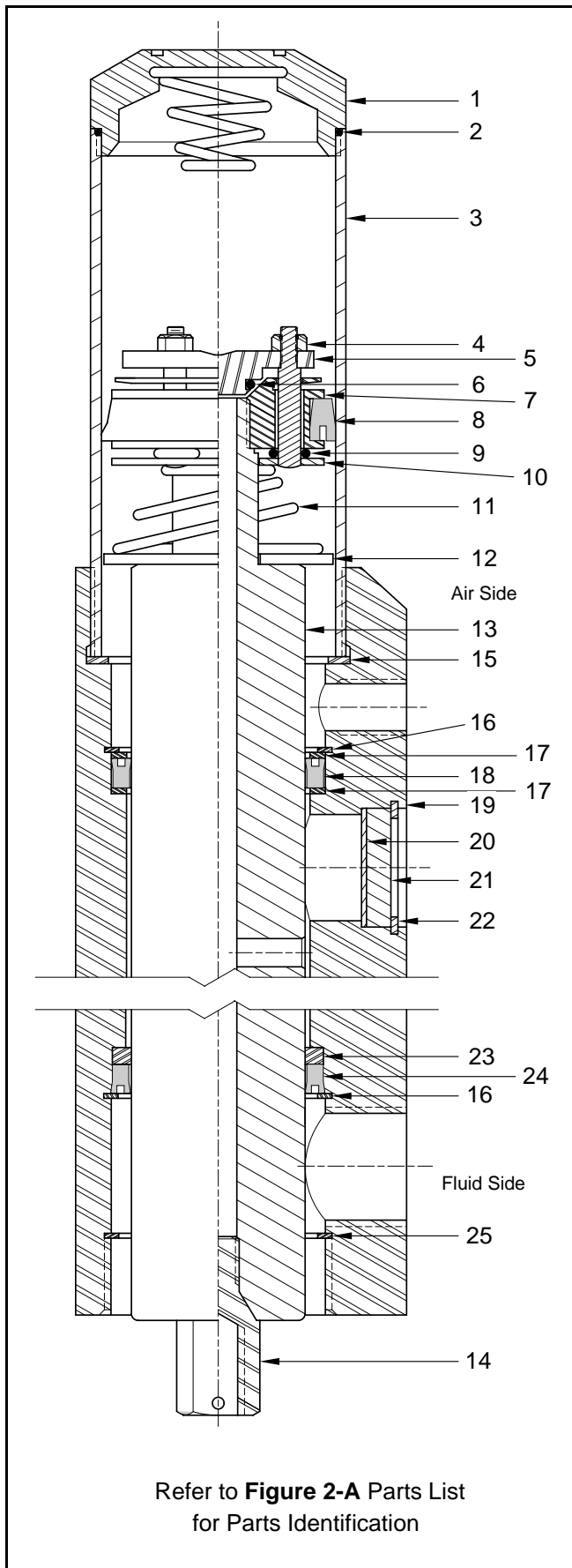

Refer to **Figure 2-A** Parts List  
for Parts Identification

9. Install Bung Adapter (**29**) onto the top of the Fluid Cylinder.

### Air Motor

**NOTE:** Refer to **Figure 6** and **Figure 2-A** for component identification on air motor assembly procedures.

### Head Assembly

10. Install O-Ring (**2**) onto Head and Spring Assembly (**1**).
11. Screw the Head Assembly into Air Cylinder (**3**).
  - User care when passing over the O-Ring.
  - Do not tighten at this time.

### Casting Body

12. Install and seat Guide Sleeve (**23**) and V-Packing (**24**) [lips outward] into the fluid side of Casting Body (**19**).
13. Install Internal Circlip (**16**) into the Casting Body.
14. Install and seat Pump Tube Seal (**25**) into the Casting Body.
15. Install and seat Packing Holder (**17**), V-Packing (**18**) [lips upward], and the additional Packing Holder into the air side of the Casting Body.
16. Install Internal Circlip (**16**) into the Casting Body.
17. Install and seat Air Cylinder Seal (**15**) into the Casting Body.
18. Install Wave Washer (**20**), Muffler (**21**), and Circlip (**22**) into the Casting Body.

### Air Piston

**IMPORTANT:** Use the proper sealant during assembly or product leakage may occur.

*Do not grip the surface of Piston (**13**) with any tool that will mar its surface. Air leakage will occur.*

19. Install Stop Washer (**12**), Conical Spring (**11**) [small diameter upward], and Air Valve Stop (**10**) [studs upward] onto the top of the Piston.
20. Install O-Rings (**9**) over the Air Valve Stop studs.
21. Place Air Piston (**7**) on the bench with the bottom face upward.

**Figure 6** Air Motor Assembly - Section View

22. Install V-Packing (8) [lips upward] onto the Air Piston.
23. Install the Air Piston assembly onto the Air Valve Stop.

*IMPORTANT: Use the proper sealant during assembly or air leakage may occur.*

---

### CAUTION

**Do not overtighten the Air Piston assembly onto the Piston. Stripping of the Piston's aluminum threads can occur.**

---

24. Screw the Air Piston onto the Piston [with Loctite 222]. See **Figure 2-A**.
  - Follow the thread sealant manufacturer's recommendations.
  - Grip the upper portion of the Air Piston with vice-grips and place an appropriate size rod into the hole of the Piston.
25. Install O-Ring (6) onto Seal Plate (5).
26. Install the Seal Plate [O-Ring downward] onto the Air Valve Stop.
27. Install Locknuts (4) that secure the Seal Plate to the Air Valve Stop.
  - Do not overtighten the Nuts.
28. Place Casting Body (19) [top upward] in a soft-jaw vise.

---

### CAUTION

**Use care installing the Piston assembly into the Casting Body. Damage to V-Packings can occur.**

---

29. Install the Piston assembly into the top of the Casting Body.
  - Ease the Piston assembly past V-Packing (18) and V-Packing (24).

30. Screw Air Cylinder (3) into the Casting Body.
  - Tighten the assembly securely with a spanner wrench on the Head and Spring Assembly.

### Attach Pump Tube to Air Motor

31. Screw the Rod assembly into Coupling (14) until the holes align.

---

### CAUTION

**Support the Coupling and Rod during Roll Pin installation. Damage to components can occur.**

---

32. Install Roll Pin (26) that secures the Coupling to Rod (27).
  - Use a small hammer.
33. Screw the Fluid Cylinder assembly into the air motor.
  - Tighten the assembly securely at the Inlet Adapter.

## Operation

### Bench Test and Prime

1. Make sure air pressure at the regulator reads zero.
2. Connect a product hose to the pump's material outlet.
3. Place the hose into an appropriate collection container.
4. Connect the air supply line to the air motor.

**NOTE:** Do not allow the pressure to exceed 50 psi (3.4 Bars).

5. Slowly apply air pressure to the pump's motor.
  - The pump assembly should cycle.

If the pump assembly does not cycle, refer to the **Troubleshooting Chart** for details.

### Priming

With air pressure at zero:

6. Place the pump in the product to be dispensed.

**NOTE:** Do not allow the pressure to exceed 50 psi (3.4 Bars).

7. Slowly supply air pressure to the pump's motor.
8. Allow the pump to cycle slowly until the system and product is free of air.

If the pump assembly does not prime, refer to the **Troubleshooting Chart** for details.

## Stall Test

**WARNING**

**Should leakage occur anywhere within the system, disconnect air to the motor. Personal injury can occur.**

With air pressure at zero:

9. Attach a control valve to the outlet hose of the pump.
10. Set the air pressure to 100 psi (6.9 Bar).
11. Operate the control valve into a container.
12. Allow the pump to cycle until the system and product is once again free of air.
13. Shut off the control valve.
  - The pump should not cycle.

If the pump cycles continuously, or once or twice a minute, refer to the **Troubleshooting Chart** for details.

14. Check the motor for air leakage.

If the motor leaks, refer to the **Troubleshooting Chart** for details.

## Installation

Additional items that should be incorporated into the air piping system are listed in **Table 5**.

Part Number	Description
338860	Moisture Separator/Regulator & Gauge Combination
5604-2	Moisture Separator
7604-B	Regulator and Gauge
5904-2	Lubricator

**Table 5** *Air Line Components*

# Troubleshooting Chart

Indications	Possible Problems	Solution
Air Motor and/or Pump does not cycle	<ol style="list-style-type: none"> <li>1. Air motor not operating properly</li> <li>2. Pump tube jammed and/or contains loose components</li> <li>3. Insufficient air pressure</li> </ol>	<ol style="list-style-type: none"> <li>1. See <b>Air Motor Assembly</b></li> <li>2. See <b>Pump Assembly</b></li> <li>3. Increase air pressure</li> </ol>
<b>Pump Assembly</b>		
Pump will not prime	<ol style="list-style-type: none"> <li>1. Excessive cycling speed</li> <li>2. Air leak before pump tube</li> <li>3. Pump leaking internally</li> </ol>	<ol style="list-style-type: none"> <li>1. Reduce air pressure</li> <li>2. Tighten connection</li> <li>3. See <b>Internal Leaks</b></li> </ol>
Pump cycles rapidly	Product source empty	Replenish product and inspect Air Motor
Pump cycles continuously, or slowly (once or twice/minute)	<ol style="list-style-type: none"> <li>1. Pump leaking internally</li> <li>2. Pump leaking externally</li> <li>3. Distribution system leaking</li> </ol>	<ol style="list-style-type: none"> <li>1. See <b>Internal Leaks</b></li> <li>2. See <b>External Leaks</b></li> <li>3. Correct leak</li> </ol>
<b>External Leaks</b>		
Product visible at top of Fluid Cylinder (28)	<ol style="list-style-type: none"> <li>1. Initial tightening of Fluid Cylinder (28) to Casting Body (19) not sufficient</li> <li>2. Damaged Seal (25)</li> </ol>	<ol style="list-style-type: none"> <li>1. Tighten Fluid Cylinder (28) into Casting Body (19)</li> <li>2. Replace Seal (25)</li> </ol>
Product visual at top of Inlet Adapter (39)	<ol style="list-style-type: none"> <li>1. Initial tightening of Inlet Adapter (39) to Fluid Cylinder (28) not sufficient</li> <li>2. Damaged O-Ring (2)</li> </ol>	<ol style="list-style-type: none"> <li>1. Tighten Inlet Adapter (39) into Fluid Cylinder (28)</li> <li>2. Replace O-Ring (2)</li> </ol>
Product visual at Muffler (21)	<ol style="list-style-type: none"> <li>1. Damaged V-Packing (24)</li> <li>2. Worn or damaged Piston (13)</li> <li>3. Initial tightening of Coupling (14) to Piston (13) not sufficient and/or improper or no sealant</li> </ol>	<ol style="list-style-type: none"> <li>1. Replace V-Packing (24)</li> <li>2. Replace Piston (13)</li> <li>3. Apply Loctite 271 to Coupling (14) and tighten</li> </ol>
<b>Internal Leaks</b>		
Pump does not prime or cycles continuously, or slowly (once or twice/minute)	<ol style="list-style-type: none"> <li>1. Foreign material between Ball (37) and Inlet Adapter (39)</li> <li>2. Foreign material between Check Valve (32) and Fluid Piston (34)</li> <li>3. Worn or damaged Ball (37)</li> <li>4. Worn or damaged Inlet Adapter (39)</li> <li>5. Worn or damaged V-Packing (33)</li> <li>6. Worn or damaged Check Valve (32)</li> <li>7. Worn or damaged Fluid Piston (34)</li> <li>8. Worn or damaged Fluid Cylinder (28)</li> </ol>	<ol style="list-style-type: none"> <li>1. Locate and eliminate source of foreign material.</li> <li>2. Disassemble pump tube, clean, inspect, and replace worn or damaged components.</li> </ol>
<b>Air Motor Assembly</b>		
<b>External Leaks</b>		
Air leakage at top of Head Assembly (1)	<ol style="list-style-type: none"> <li>1. Initial tightening of Head Assembly (1) to Air Cylinder (3) not sufficient</li> <li>2. Damaged O-Ring (2)</li> </ol>	<ol style="list-style-type: none"> <li>1. Tighten Head Assembly (1) to Air Cylinder (3)</li> <li>2. Replace O-Ring (2)</li> </ol>
Air leakage at top of Casting Body (19)	<ol style="list-style-type: none"> <li>1. Initial tightening of Air Cylinder (3) to Casting Body (19) not sufficient</li> <li>2. Damaged Seal (15)</li> </ol>	<ol style="list-style-type: none"> <li>1. Tighten Air Cylinder (3) to Casting Body (19)</li> <li>2. Replace Seal (15)</li> </ol>
<b>Internal Leaks</b>		
Air leakage felt at Muffler (21)	<ol style="list-style-type: none"> <li>1. Worn or damaged Spring in Head and Spring Assembly (1)</li> <li>2. Foreign material between Seal Plate (5) and Air Piston (7)</li> <li>3. Initial tightening of Piston (13) to Air Piston (7) not sufficient and/or improper or no sealant</li> <li>4. Worn or damaged O-Ring (6)</li> <li>5. Worn or damaged V-Packing (8)</li> <li>6. Worn or damaged O-Ring (9)</li> <li>7. Worn or damaged Spring (11)</li> <li>8. Worn or damaged V-Packing (18)</li> <li>9. Worn or damaged Piston (13)</li> </ol>	<ol style="list-style-type: none"> <li>1. Disassemble air motor, clean, inspect, and replace worn or damaged components. Reduce air pressure.</li> <li>2. Locate and eliminate source of foreign material.</li> <li>3. Apply Loctite 222 to Piston (13) and tighten</li> <li>4. Disassemble air motor, clean, inspect, and replace worn or damaged components.</li> </ol>

**Changes Since Last Printing**

Initial Release