

Transfer Pump

Description

The major components of transfer “stick” pump model 7216-4 consist of a differential air-operated motor and a double-acting reciprocating pump tube.

This low-pressure (1:1 ratio) pump includes a 2 " PT (m) bung adapter that allows installation directly onto 55-gallon (200/205 l) drums.

The air motor is equipped with a shut-off valve that allows pump operation without a fluid control valve.

The pump is designed to transfer fluids compatible with a fluid-wetted path of carbon steel, aluminum, Teflon, and nylon 11.

Specifications

Differential Air Motor

Piston Diameter x Stroke		Effective Piston Area *		Air Inlet	Maximum Air Pressure	
In	Cm	In ²	Cm ²		psi	Bars
2-1/16 x 4	5.2 x 10.2	1.67	10.8	1/4 " NPTF (f)	200	13.8

* The effective piston area of a differential air motor is equal to one-half the actual area of the piston.
For details on the air motor, refer to Service Guide SER 318450-4

Pump Tube

Fluid Outlet	Maximum Fluid Pressure		Max. Free-Flow Delivery/Minute *		Displacement per Cycle	
	psi	Bars	Gallons	Liters	In ³	Cm ³
1 " NPTF (f)	200	13.8	14	53	10.5	172

See **Figure 3** for performance curves.
* SAE 10 oil at 75 ° F (24 ° C) and 100 psi (6.9 Bars) air pressure

Table 1 Transfer Pump Specifications

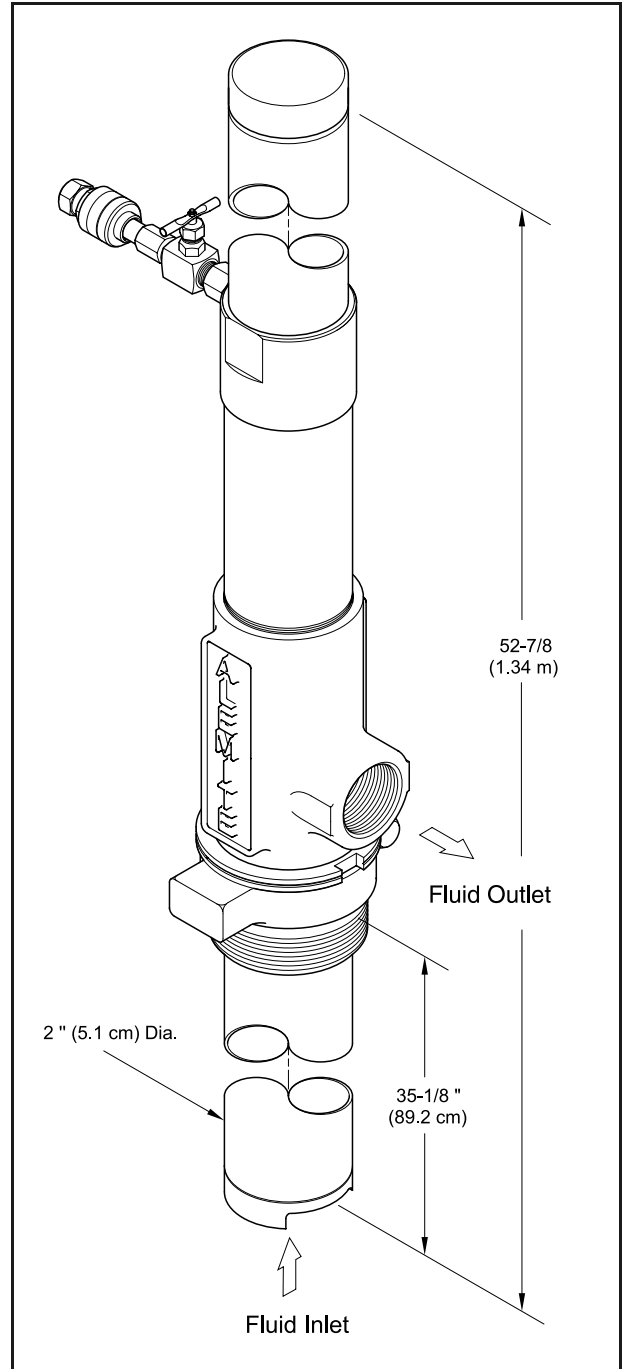

Figure 1 Transfer Pump Model 7216-4

Alemite Corporation
PO Box 473515, Charlotte, North Carolina 28247-3515
www.alemite.com

Copyright © 2000 by Alemite Corporation

This document contains confidential information that is the property of Alemite Corporation and is not to be copied, used, or disclosed to others without express written permission.

SER 7216-4
Revision (5-00)

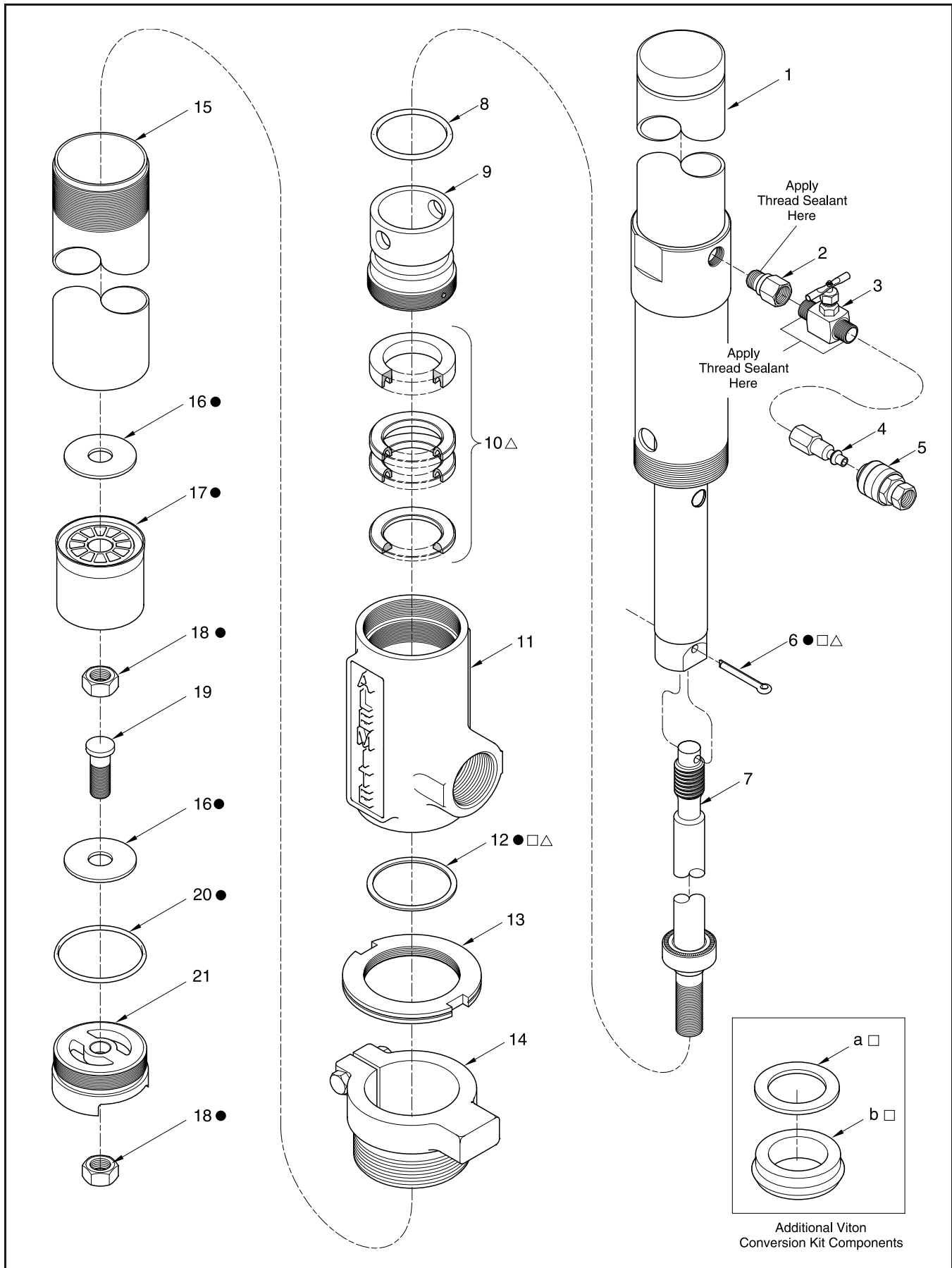

Figure 2 Transfer Pump Model 7216-4 - Exploded View

Item No.	Part No.	Description	Qty	Notes	Numeric Order Part # (Item #)
1		Motor Assembly, Air	1	See SER 318450-4	(1)
2	53176	Adapter, 1/4 " NPTF (m) x 1/4 " NPTF (f)	1		51917 (16)
3	319391	Valve, 1/4 " PT (m)	1		51929 (18)
4	B330605	Adapter, 1/4 " NPTF (f)	1		53176 (2)
5	328030	Coupler, Air, 1/4 " NPTF (f)	1		X171000-29 (8)
6		Pin, Cotter, 1/8 " Dia. x 1.00 " Long	1	●△□	<i>172191-1</i> (b)
7	337692-A1	Rod and Stop Assembly, 31-5/8 " Long	1		<i>172212-16</i> (6)
8	X171000-29	O-Ring, 1-5/8 " ID x 2 " OD	1	●	Pack of Ten (10) 318479-3 (11)
9	318778	Bushing Assembly (w/ nylon insert)	1		318487-2 (15)
10	336503	Packing Set (Teflon) (4 pieces)	1	●△	318778 (9)
11	318479-3	Body	1		319391 (3)
12	319436	Gasket (Aluminum)	1	●△□	319436 (12)
13	333348	Nut, Jam	1		319678 (20)
14	326750-B1	Adapter, Bung, 2 " NPTF (m)	1		326750-B1 (14)
15	318487-2	Cylinder, 36-1/4 " Long	1		328030 (5)
16	51917	Washer	2	●	B330605 (4)
17	337693	Plunger (Nylon-11)	1	●	333348 (13)
18	51929	Nut, Elastic Stop, 3/8 " -24	2	●	336503 (10)
19	337689	Stud	1		<i>337139</i> (a)
20	319678	O-Ring, 1.812 " ID x 1.952 " OD	1	●	337689 (19)
21	337690	Valve, Base	1		337690 (21)
Additional Components Included in Viton Conversion Kit					337692-A1 (7)
a		Washer, Back-Up (Brass)		□	Replace Item 10 337693 (17)
b		Seal, 1-3/8 " ID x 2 " OD (Viton)		□	
Legend:					
Part numbers left blank (or in <i>italics</i>) are not available separately					
● △ □ designates a repair kit item					

Repair Kits

Part No.	Kit Symbol	Description
393729	●	Kit, Major Repair
393640	△	Kit, Minor Repair (Teflon)
393488	□	Kit, Conversion (Viton)

Performance Curves

A pump's ability to deliver fluid is based on the pressure (psi/Bars) and quantity (cfm/lpm) of air supplied to the motor and the amount of fluid discharge [back] pressure to be overcome within the system.

This chart contains curves based on three different air pressures.

The curves relate delivery in gallons (liters) per minute (X axis) to air consumption in cubic feet (liters) per minute (right Y axis) and to fluid discharge pressure in psi/Bars (left Y axis).

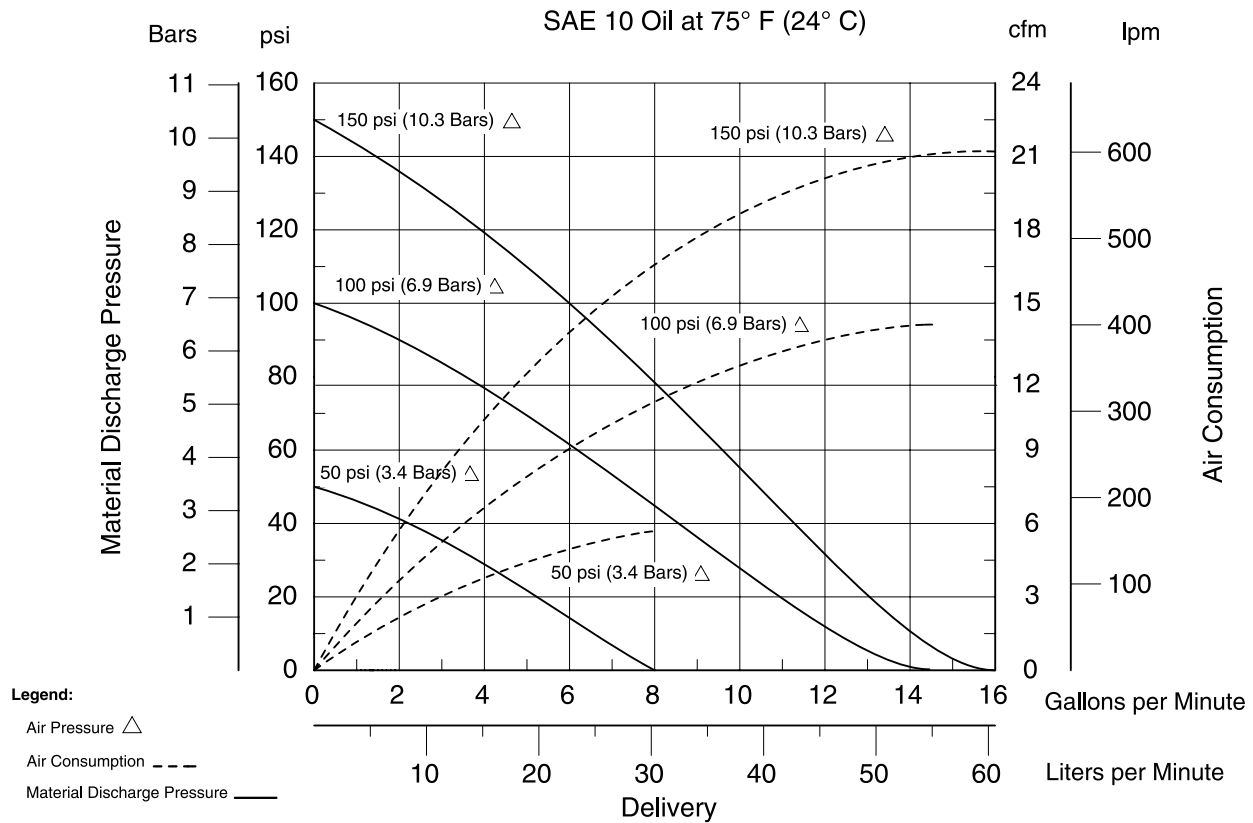

Figure 3 Delivery versus Discharge Pressure and Air Consumption

Overhaul

NOTE: Refer to **Figure 2** for component identification on all overhaul procedures.

Prior to performing any maintenance procedure, the following safety precautions must be observed. Personal injury may occur.



WARNING

Do not use halogenated hydrocarbon solvents such as methylene chloride or 1,1,1-trichloroethane in this pump. An explosion can result when aluminum and/or zinc-plated parts in the pump come in contact with halogenated hydrocarbon solvents.

Release all pressure within the system prior to performing any overhaul procedure.

- **Disconnect the air supply line from the pump motor.**
- **Into an appropriate container, operate the control valve to discharge remaining pressure within the system.**

Never point a control valve at any portion of your body or another person. Accidental discharge of pressure and/or fluid can result in injury. Read each step of the instructions carefully. Make sure a proper understanding is achieved before proceeding.

Disassembly

Separate Pump Tube from Air Motor

1. Clamp Body (11) horizontally in a soft-jaw vise.
2. Loosen Jam Nut (13) that secures the pump tube assembly to the Body.

CAUTION

Support the pump tube assembly during removal. Damage to components can occur.

3. Unscrew Cylinder (15) from the Body.
 - Remove the Cylinder [with attached components].

4. Pull on Rod and Stop Assembly (7) to expose the end of the air motor's piston as required.
5. Remove Cotter Pin (6) that secures the air motor's piston to the Rod and Stop Assembly.
6. Unscrew the Rod and Stop Assembly from the air motor's piston.
7. Unscrew and remove Air Motor Assembly (1) from the Body.

Pump Tube Assembly

Body Assembly

8. Remove Gasket (12) from the bottom of the Body.
9. Unscrew Bushing Assembly (9) from the Body.
 - Remove O-Ring (8) from the Bushing Assembly.
10. Remove Packing group (10) from the Body.

HINT: Evenly tap the bottom Packing of the group with a wide-blade flat-head screwdriver.

Cylinder Assembly

11. Unscrew Nut (18) that secures Plunger (17) to the Rod and Stop Assembly.
 - Remove the Plunger and Washer (16) from the Rod and Stop Assembly.
12. Unscrew Base Valve (21) [with attachments] from Cylinder (15).
 - Remove O-Ring (20) from the Base Valve.
13. Unscrew Nut (18) that secures Stud (19) to the Base Valve.
14. Remove the Stud and Washer (16) from the Base Valve.
15. Remove the Jam Nut and Bung Adapter (14) from the Cylinder as required.

Clean and Inspect

*IMPORTANT: If the pump is equipped with a worn old style plunger and/or ring assembly (See **Figure 4**), make sure to also purchase the current Rod and Stop Assembly (7).*

1. Clean all metal parts in cleaning solvent. The solvent should be environmentally safe.
2. Inspect all parts for wear and/or damage.
 - Replace as necessary.
3. Inspect Plunger (17) for wear.
 - Replace as necessary.
4. Inspect bore of Cylinder (15) for any score marks.
 - Replace as necessary.
5. Closely inspect the mating surfaces of all check valve components for any imperfections. Ensure a smooth and clean contact is obtained when assembled.

Assembly

NOTE: Prior to assembly, certain components require lubrication. Refer to **Table 2** for details.

Pump Tube Assembly

Body

1. Clamp Body (11) in a soft-jaw vise.
2. Install and seat Packing group (10) into the Body.
 - See **Figure 2** and/or **5** for the proper sequence and orientation.
 - Use care passing the threads of the Body.
3. Install O-Ring (8) onto Bushing Assembly (9).

Item No.	Description
Grease	
1	bore contacted by O-Ring (8)
8	O-Ring, 1-5/8 " ID x 2 " OD
Clean Oil	
10	Packing Set (Teflon) (4 pieces)
15	bore of Cylinder
20	O-Ring, 1.812 " ID x 1.952 " OD

Table 3 Lubricated Components

4. Screw the Bushing Assembly into the Body loosely.
5. Screw Air Motor Assembly (1) into the Body.
 - Do not tighten at this time.
 - Allow the hole in the Bushing Assembly to completely show through the hole in the Air Motor Assembly.

*IMPORTANT: The Bushing Assembly will require adjustment. Refer to the section entitled **Bench Test and Operation** for details.*

6. Install Gasket (12) into the Body.

Rod and Stop Assembly

7. Install Washer (16) and Plunger (17) onto the bottom of Rod and Stop Assembly (7).
 - Make sure to orient the Plunger properly.
8. Install Nut (18) onto the Rod and Stop Assembly.
 - Tighten the Nut to 30 inch-pounds (3.4 Nm).
9. Screw the Rod and Stop Assembly into the piston of the Air Motor Assembly.
 - Make sure the cotter pin holes align.
10. Install Cotter Pin (6) that secures the Piston Assembly to the Rod and Stop Assembly.

Base Valve and Cylinder Assembly

11. Install O-Ring (20), Washer (16), and Stud (19) onto Base Valve (21).
12. Install Nut (18) onto the Stud.
 - Tighten the Nut securely.
13. Screw the Base Valve assembly into Cylinder (15).
 - Do not tighten at this time.
14. Screw Jam Nut (13) onto the Cylinder as required.
15. Install the Cylinder [with attached components] onto the Plunger.
 - Use care not to damage the lip of the Plunger.

Connect Pump Tube to Air Motor

16. Screw the Cylinder into the Body.
 - Make sure the Gasket has not moved.
17. Tighten the Base Valve into the Cylinder and at the same time the Cylinder into the Body.
 - Make sure to properly crush the Gasket.
18. Tighten the Jam Nut that secures Cylinder to the Body.
19. Install Bung Adapter (14) onto the Cylinder.

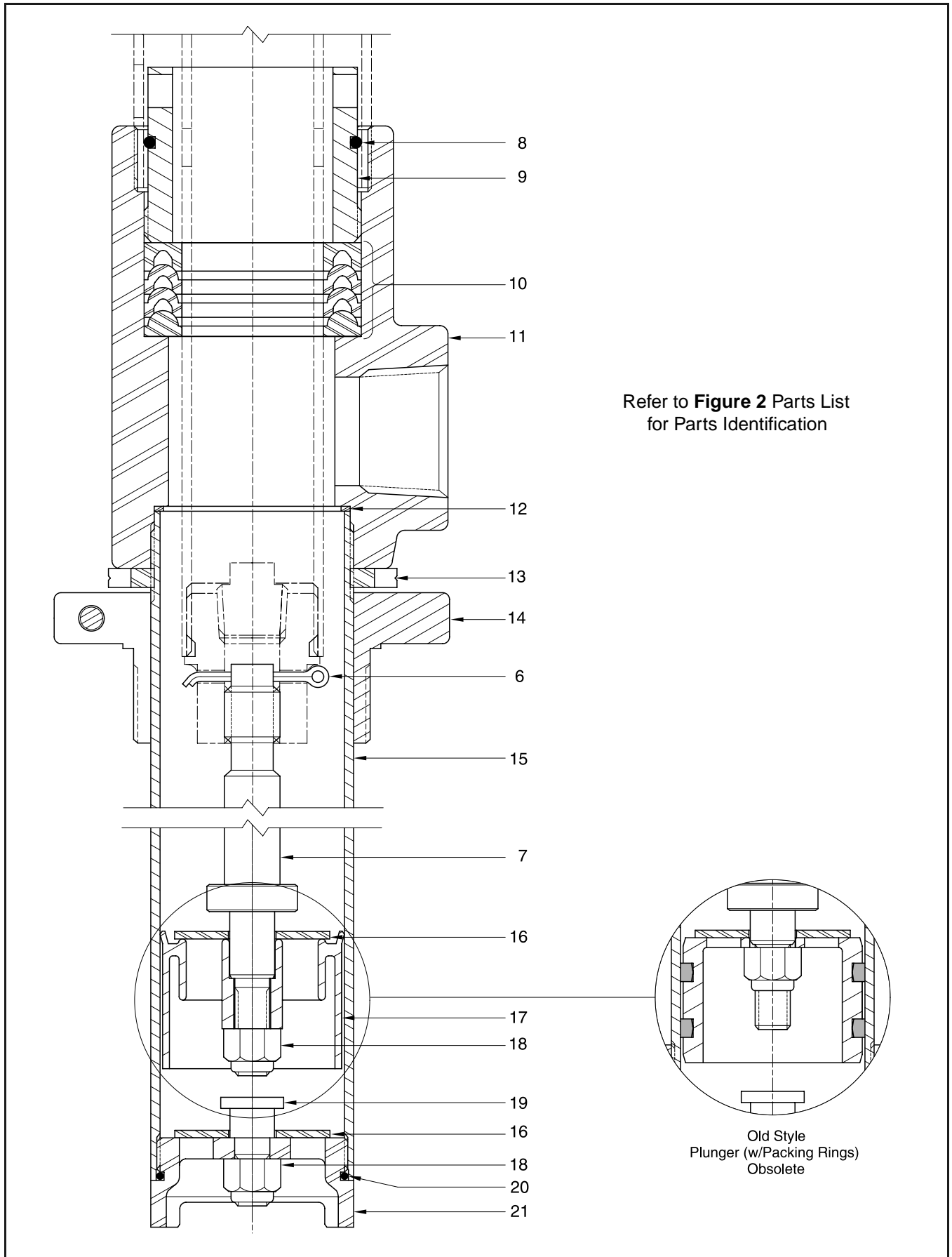

Figure 4 Pump Tube Assembly - Section View

Bench Test and Operation



WARNING

Do not exceed the lowest pressure rating of any component in the system.

Ensure all components are in operable condition. Replace any suspect parts prior to operation.

Should leakage occur anywhere within the system, disconnect air to the motor. Personal injury can occur.

Establishing Starting Pressure

1. Make sure air pressure at the regulator reads zero.
2. Screw Adapter (2) [with thread sealant] into the inlet of the Air Motor Assembly.
3. Screw Valve (3) [with thread sealant] into the Adapter.
4. Screw Adapter (4) into the Valve [with thread sealant].
 - Tighten the Adapter securely.
5. Install Air Coupler (5) onto the air supply line.
6. Connect the Air Coupler to the Adapter.

IMPORTANT: The pump must begin to cycle once the air pressure reaches 30 psi (2.1 Bars).

7. Slowly supply air pressure [not to exceed 30 psi (2.1 Bars)] to the pump's motor.
 - The pump assembly should cycle.

If the pump assembly does not cycle at 30 psi (2.1 Bars), the Bushing Assembly may require adjustment.

NOTE: The pump may not cycle for additional reasons. Refer to the **Troubleshooting Chart** for details.

Bushing Assembly Adjustment

8. Turn off the air pressure.
9. Unscrew the Air Motor Assembly until the hole in the Air Motor aligns with one of the holes in the Bushing Assembly as required.

IMPORTANT: Observe the Bushing Assembly. It will either remain stationary or unscrew with the Air Motor Assembly.

Should the Bushing Assembly remain stationary:

10. Insert a rod through the hole in the Air Motor and into the hole of the Bushing Assembly.
11. Slowly supply air pressure [not to exceed 30 psi (2.1 Bars)] to the pump's motor.
12. Adjust the load on the Packing group until the pump begins to cycle at 30 psi (2.1 Bars).
13. Turn off the air pressure.
14. Tighten the Air Motor Assembly securely into the Body.

Should the Bushing Assembly turn with the Air Motor Assembly:

15. Unscrew the Air Motor Assembly completely from the Body.
 - Separate the Bushing from the Adapter of the Air Motor.
16. Apply an additional coat of grease to the O-Ring and the bore of the Air Motor Assembly that contacts the O-Ring.
17. Screw the Bushing Assembly into the Body hand-tight.
18. Screw the Air Motor Assembly into the Body until the hole in the Air Motor's adapter aligns with one of the holes in the Bushing Assembly.
19. Follow procedural steps **10 - 14**.

Initial Prime

With air pressure at zero:

20. Connect a product hose to the pump's fluid outlet.
 - Direct the hose into an appropriate collection container.
21. Place the pump in the fluid to be dispensed.
22. Slowly supply air pressure to the pump's motor.
23. Allow the pump to cycle slowly until the fluid is free of air.

If the pump assembly does not prime, refer to the **Troubleshooting Chart** for details.

Leakage and Stall



WARNING

Should leakage occur anywhere within the system, disconnect air to the motor. Personal injury can occur.

With air pressure at zero:

24. Attach a control valve to the outlet hose of the pump.
 - Make sure the nozzle on the control valve is open.
25. Slowly supply air pressure to the pump's motor.
26. Allow the pump to cycle slowly until the fluid is once again free of air.
27. Set the air pressure to the normal operating pressure.
28. Operate the control valve into a container.
29. Shut off the control valve.
 - Visually inspect the pump for external leaks.
 - The pump should not cycle more than once or twice in one hour.

If the pump does not stall, refer to the **Troubleshooting Chart** for details.

30. Check the motor for air leakage.

If the motor leaks, refer to the **Air Motor Service Guide** for details.

Installation

Additional items that should be incorporated into the air piping systems are listed in **Table 3**.

Part Number	Description
5604-2	Moisture Separator
7604-B	Regulator and Gauge

Table 3 *Air Line Components*

Troubleshooting Chart

Pump Indications	Possible Problems	Solution
Pump does not cycle	<ol style="list-style-type: none"> 1. Packings (10) too tight 2. Air motor not operating properly 3. Pump tube jammed and/or contains loose components 4. Insufficient air pressure 	<ol style="list-style-type: none"> 1. Adjust Bushing Assembly (9) 2. Inspect air motor and rebuild or replace as necessary 3. Rebuild pump tube 4. Increase air pressure
Pump will not prime	<ol style="list-style-type: none"> 1. Excessive cycling speed 2. Pump leaking internally 	<ol style="list-style-type: none"> 1. Reduce air pressure 2. See Internal Leaks
Pump cycles rapidly	Product source empty	Replenish product
Pump will not stall (cycles more than once or twice/hour)	<ol style="list-style-type: none"> 1. Pump requires break-in period 2. Pump leaking internally 3. Pump leaking externally 4. Distribution system leaking 	<ol style="list-style-type: none"> 1. Operate the pump against moderate fluid pressure for up to one hour 2. See Internal Leaks 3. See External Leaks 4. Correct leak
External Leaks		
Product leakage visible at bottom of Body (11)	<ol style="list-style-type: none"> 1. Damaged Gasket (12) 2. Cylinder (15) not sufficiently tight 	<ol style="list-style-type: none"> 1. Replace Gasket (12) 2. Tighten Cylinder (15) into Body (11)
Product leakage at exhaust port in Air Motor Assembly (1)	<ol style="list-style-type: none"> 1. Packings (10) too loose 2. Worn or damaged Packing group (10) 3. Worn or damaged air motor piston rod 	<ol style="list-style-type: none"> 1. Adjust Bushing Assembly (9) 2. Use Kit 393640 3. Replace air motor piston rod
Product leakage between Cylinder (15) and Base Valve (21)	<ol style="list-style-type: none"> 1. Worn or damaged O-Ring (20) 2. Base Valve (21) not sufficiently tight 	<ol style="list-style-type: none"> 1. Replace O-Ring (20) 2. Tighten Base Valve (21) into Cylinder (15)
Internal Leaks		
Pump does not prime or cycles continuously, or slowly (once or twice/hour)	<ol style="list-style-type: none"> 1. Foreign material between Washer (16) and Base Valve (21) 2. Foreign material between Washer (16) and Plunger (17) 3. Worn or damaged Washer (16) 4. Worn or damaged Base Valve (21) 5. Worn or damaged Plunger (17) 	<p>Locate and eliminate source of foreign material</p> <p>Disassemble pump tube, clean, inspect, and replace worn or damaged components</p>

Changes Since Last Printing

Deleted Conversion Kits 393551-1 and 393552
 Changed Major Repair Kit to 393729