

Medium-Pressure Bulk Grease Pump

Description

The major components of pump model 7736 consist of an air-operated motor and a pump tube. The air motor connects directly to the double-acting reciprocating pump tube.

This medium-pressure (11:1 ratio) grease pump is designed to transfer a range of greases [up to NLGI # 3] from bulk containers to smaller containers.

Mounting

In most cases these pumps connect horizontally to a bulk container. See **Figure 5**. The pump includes the male portion of a 3-inch camlock connection for ease in installation.

Material Delivery Hose and Control Valve

The use of the proper size delivery hose and control valve (if used) is essential to optimize flow rate. A hose that is excessively long or with too small an inside diameter will restrict product flow.

Both components must have a pressure rating that allows safe operation at the maximum anticipated pump pressure.

Air Motor

Piston Diameter x Stroke		Air Inlet / Outlet	Max. Air Pressure	
Inches	Centimeters		psi	Bars
6 x 4	15.2 x 10.2	3/4 " NPTF (f)	100	6.9

For information on the air motor, refer to Service Guide SER 323640-E1

Pump Tube

Material Outlet	Max. Material Pressure		Max. Delivery/Minute (Approximate)*		Displacement per Cycle	
	psi	Bars	Pounds	Kilograms	in ³	cm ³
1-1/4 " NPTF (f)	1100	75.9	86	39	16.5	270.4

* For detailed information, refer to **Figure 3**

Table 1 7736 Model Series Specifications

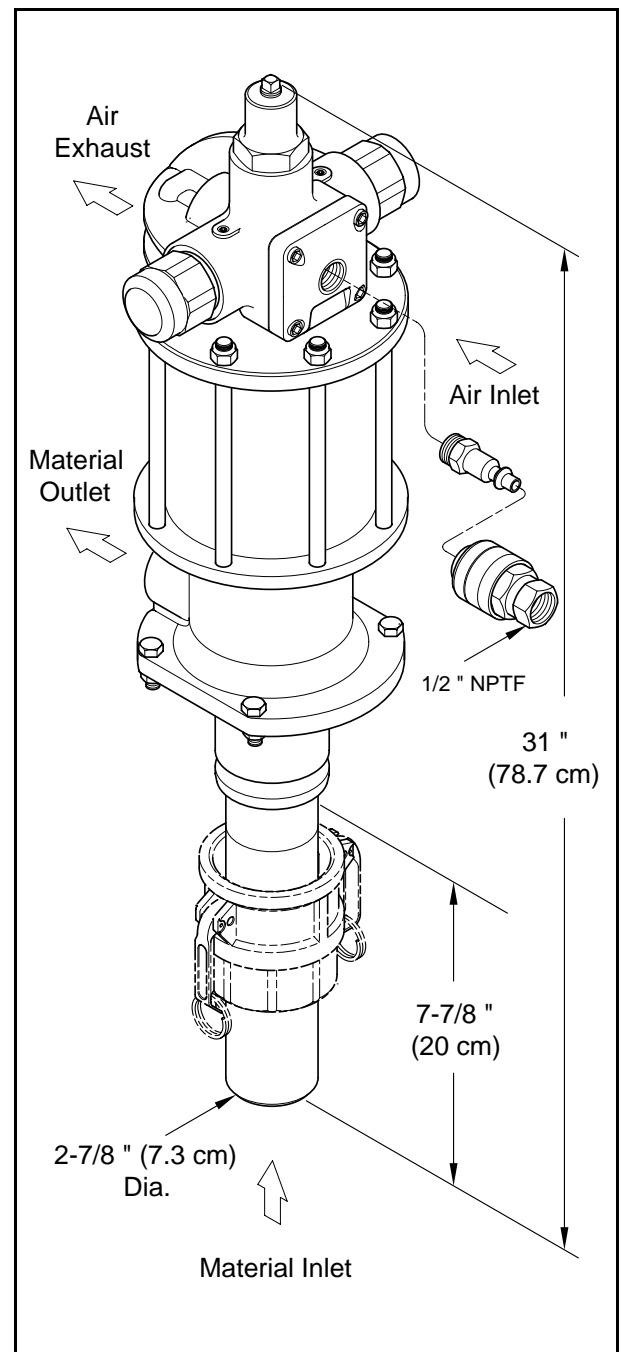

Figure 1 Medium-Pressure Bulk Grease Pump Model 7736

Alemite Corporation
PO Box 473515, Charlotte, North Carolina 28247-3515

Copyright © 1996 by Alemite Corporation

This document contains confidential information that is the property of Alemite Corporation and is not to be copied, used, or disclosed to others without express written permission.

SER 7736
Revision (11-96)

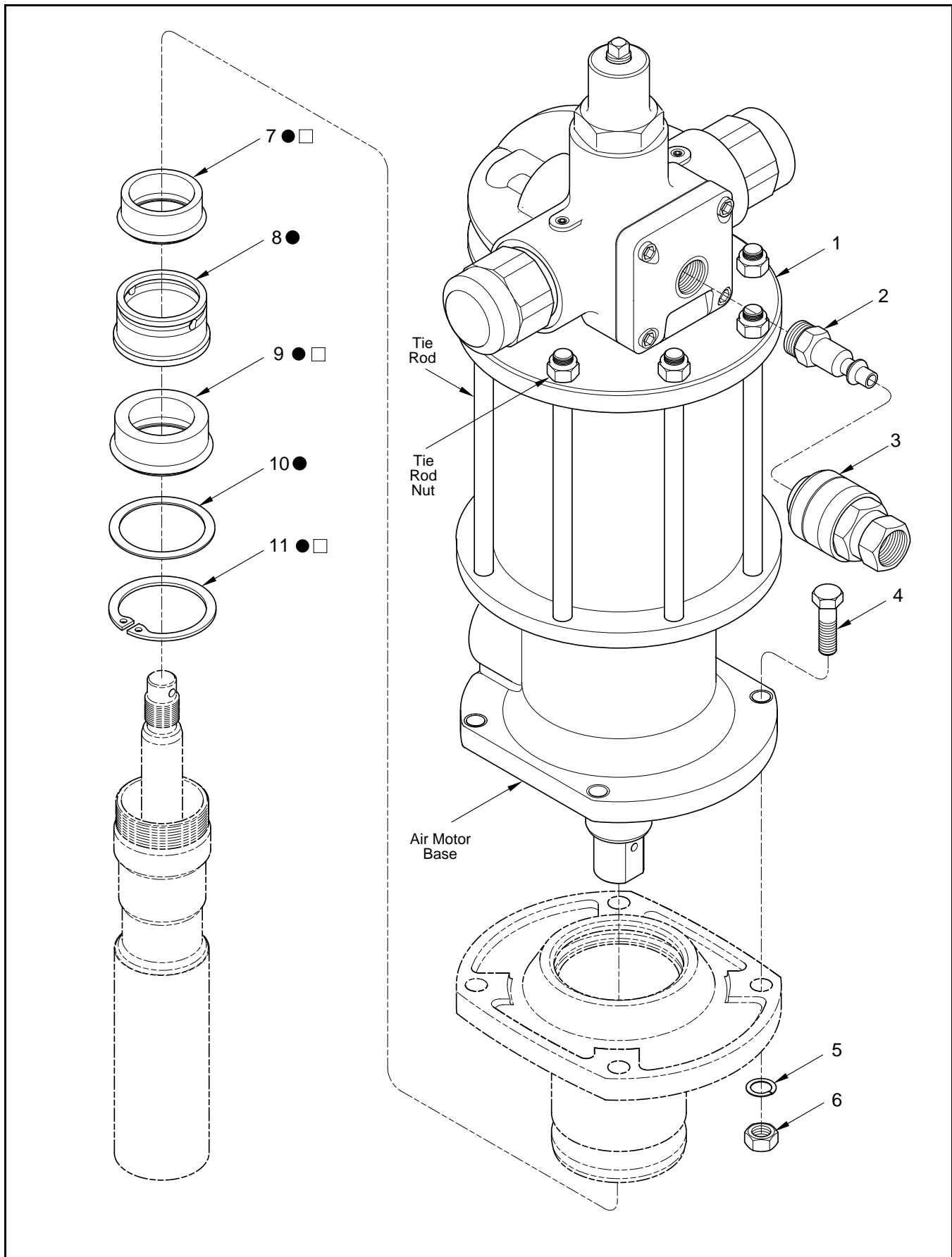

Figure 2-A Medium-Pressure Bulk Grease Pump Model 7736 - Exploded View

Item No.	Part No.	Description	Qty	Notes	Numeric Order Part # (Item #)
1		Motor Assembly, Air	1	See SER 323640-E1	11828 (4)
2	328037	Connector, 3/4 " NPTF (m)	1		77807 (6)
3	328031	Coupler, Air, 1/2 " NPTF (f)	1		171006-49 (11)
4		Screw, 1/2 " -20 x 2 "	4		172190-36 (7)
5		Lockwasher, 1/2 "	4		172207-4 (5)
6		Nut, 1/2 " -20	4		323640-E1 (1)
7		Seal, 1-7/8 " ID x 2-3/8 " OD	1	● □	328031 (3)
8		Bearing (Brass)	1	●	328037 (2)
9		Seal, U-Cup, 1-7/8 " ID x 2-1/2 " OD	2	● △ □ *	338824-4 (9)
10		Washer, 1.935 " ID	1	●	338842 (10)
11	171006-49	Circlip, Internal	1	● □	338843 (8)

Legend:
 Part numbers left blank (or in *italics*) are not available separately
 ● △ □ designates a repair kit item
 * Quantity of one (1) in each of the Minor Repair Kits

Repair Kits

Part No.	Kit Symbol	Description	Notes
393670	●	Kit, Major Repair	Includes items on Figure 2-A and 2-B
393671	△	Kit, Minor Repair (for Lower Tube Assembly)	Includes items on Figure 2-A and 2-B
393672	□	Kit, Minor Repair (for Upper Packing Group)	Includes items on Figure 2-A and 2-B
393530-36		Kit, Seal [includes five (5) of item number 7]	

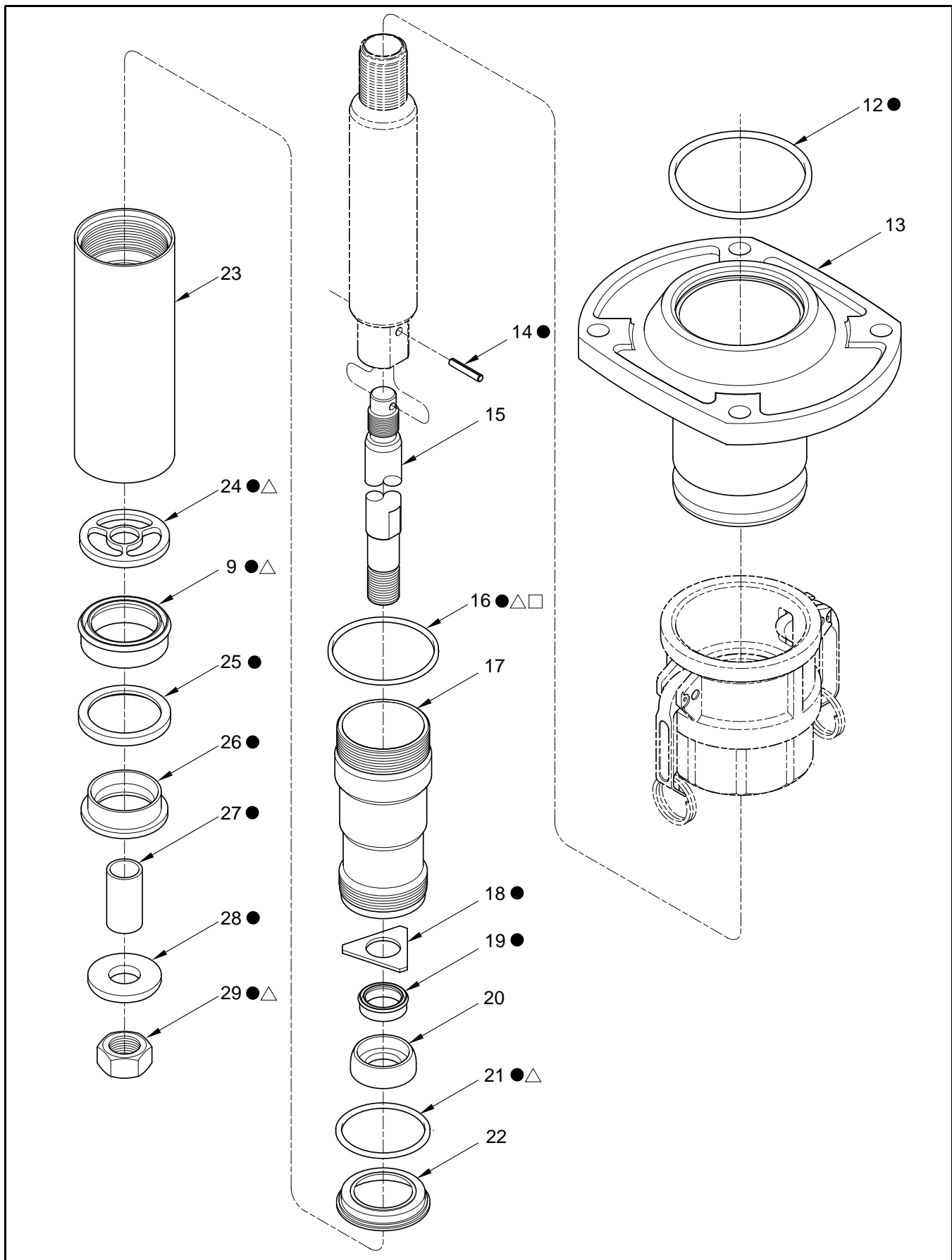

Figure 2-B Medium-Pressure Bulk Grease Pump Model 7736 - Exploded View

Item No.	Part No.	Description	Qty	Notes	Numeric Order Part # (Item #)
12	171000-107	O-Ring, 4 " ID x 4-3/8 " OD	1	●	171000-107 (12)
13	338838	Adapter, Camlock	1		<i>171009-43</i> (21)
14		Pin, Roll, 5/32 " x 1 "	1	●	<i>171009-45</i> (16)
15	338844	Rod, Lower	1		<i>171034-9</i> (14)
16		O-Ring, 2-9/16 " ID x 2-3/4 " OD	1	● △ □	<i>171425</i> (29)
17	338850	Tube, Upper	1		<i>338824-5</i> (19)
18	338849	Stop, Valve	1	●	338838 (13)
19		Seal, U-Cup, 3/4 " ID x 1-1/4 " OD	1	●	<i>338841</i> (25)
20	338851	Valve, Check	1		338844 (15)
21		O-Ring, 2-7/16 " ID x 2-5/8 " OD	1	● △	<i>338845</i> (27)
22	338852	Seat, Upper Valve	1		338846 (23)
23	338846	Tube, Lower	1		338847 (24)
24	338847	Guide	1	● △	<i>338848</i> (26)
25		Ring, Support	1	●	338849 (18)
26		Seat, Lower Valve	1	●	338850 (17)
27		Spacer	1	●	338851 (20)
28	338853	Plate, Valve	1	●	338852 (22)
29		Nut, Elastic Stop, 5/8 " -18	1	● △	338853 (28)

Legend:

Part numbers left blank (or in *italics*) are not available separately

● △ □ designates a repair kit item

Repair Kits

Part No.	Kit Symbol	Description	Notes
393670	●	Kit, Major Repair	Includes items on Figure 2-B and 2-A
393671	△	Kit, Minor Repair (for Lower Tube Assembly)	
393672	□	Kit, Minor Repair (for Upper Packing Group)	Includes items on Figure 2-B and 2-A

Accessories

Part Number	Description
324170	Muffler

Table 2 Model 7736 Accessories

Preventive Maintenance

Refer to section entitled **Overhaul** for the procedures necessary to perform maintenance.

Daily	Weekly	Monthly	Yearly
Wipe Exterior with Clean Cloth	Inspect for Air and/or Material Leakage		

Table 3 Model 7736 Preventive Maintenance Schedule

Performance Curves

A pump's ability to deliver material is based on the pressure (psi/Bars) and quantity (cfm/lpm) of air supplied to the motor and the amount of material discharge [back] pressure to be overcome within the system.

This chart contains curves based on three different air pressures. The curves relate delivery in pounds (kilograms) per minute (X axis) to air consumption in cubic feet (liters) per minute (right Y axis) and to material discharge pressure in psi/Bars (left Y axis).

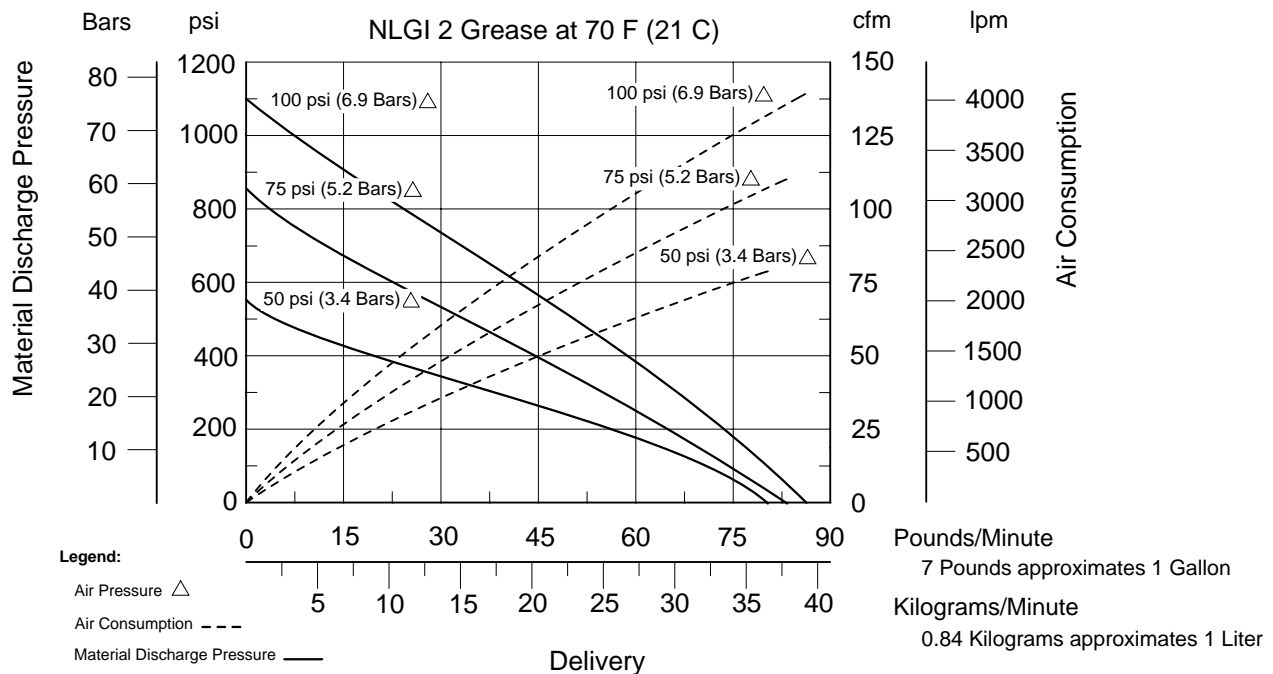
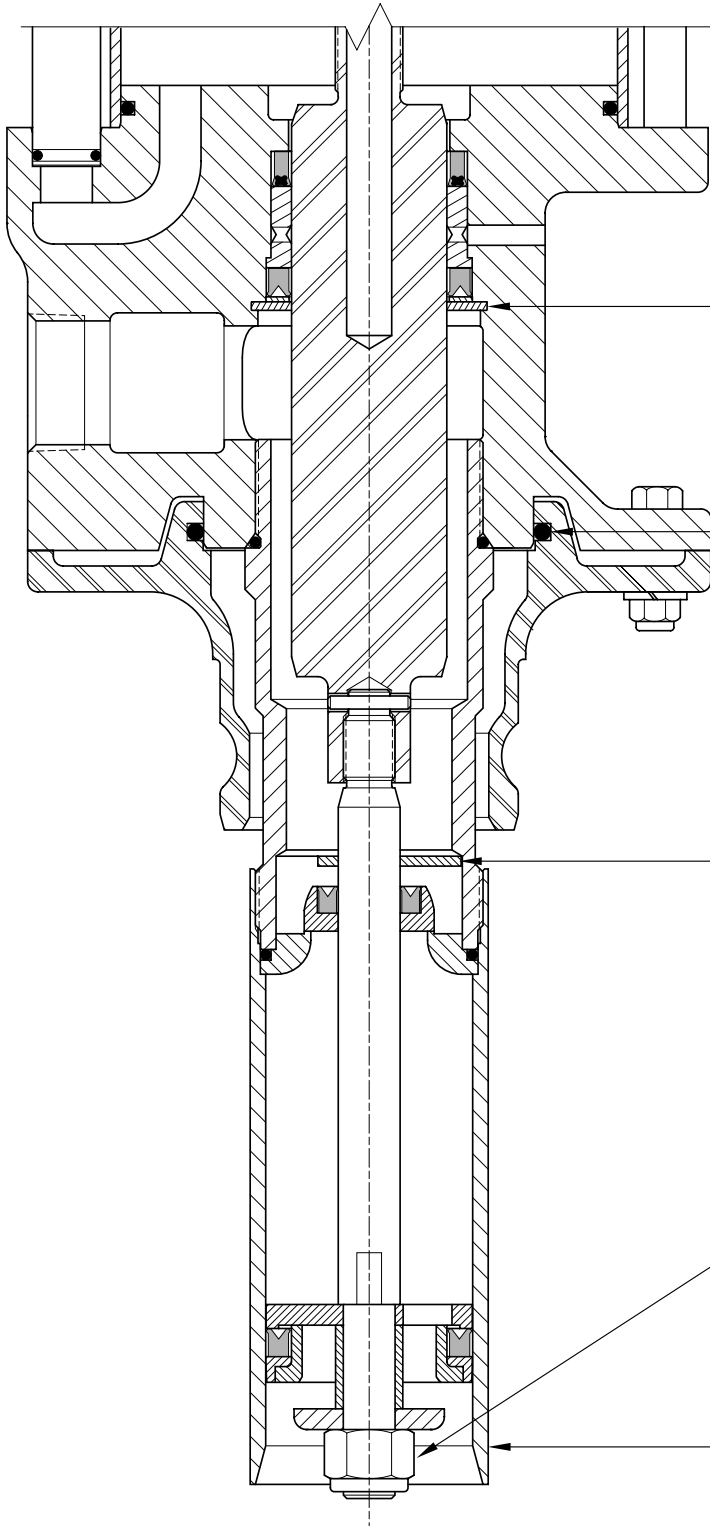

Figure 3 Delivery versus Discharge Pressure and Air Consumption

Service Hints

Refer to the Overhaul Procedures for Details



Use Internal Circlip Pliers
such as Truarc # 0700-10
to Remove Circlip

Damage to Circlip may Occur

Coat Inside Diameter of O-Ring
with Grease Prior to Assembly

Damage to O-Ring can Occur

Inspect Valve Stop to Ensure Proper Seat
in Upper Tube

Pump Leakage will Occur

Do not Overtighten Nut

Damage to Brass Guide
can Occur

Keep End of Lower Tube
Free from Foreign Material

Leakage may Occur

Overhaul

NOTE: Refer to **Figure 2-A** and **2-B** for component identification on all overhaul procedures.

Prior to performing any maintenance procedure, the following safety precautions must be observed. Personal injury may occur.



WARNING

Do not use halogenated hydrocarbon solvents such as methylene chloride or 1,1,1-trichloroethane in this pump. An explosion can result within an enclosed device capable of containing pressure when aluminum and/or zinc-plated parts come in contact with halogenated hydrocarbon solvents.

Release all pressure within the system prior to performing any overhaul procedure.

- Disconnect the air supply line from the pump motor.
- Into an appropriate container, operate the control valve to discharge remaining pressure within the system.

Never point a control valve at any portion of your body or another person. Accidental discharge of pressure and/or material can result in injury.

Read each step of the instructions carefully. Make sure a proper understanding is achieved before proceeding.

Disassembly

Separate Pump Tube from Air Motor

1. Clamp the motor in a vise.
2. Remove Nuts (6), Lockwashers (5), and Screws (4) that secure Camlock Adapter (13) to Air Motor Assembly (1).
 - Remove the Camlock Adapter from the Air Motor Assembly.
3. Remove O-Ring (12) from the Camlock Adapter.
4. Unscrew Upper Tube (17) from the air motor base.
 - Use a strap wrench.

CAUTION

Do not apply excessive force during the separation of the pump tube from the air motor. Damage to Valve Stop (18) can occur.

5. Pull the Upper Tube away from the Air Motor to expose Lower Rod (15).

CAUTION

Support the Lower Rod assembly and piston rod during Roll Pin (14) removal. Damage to components can occur.

6. Remove Roll Pin (14) that secures the Lower Rod to the piston rod.
 - Use a punch and a small hammer.
7. Place a socket wrench on Nut (29) and unscrew the Lower Rod assembly from the piston rod.

Pump Tube Upper Packing

NOTE: The base of the air motor must be removed to access the upper packing group of the pump tube.

8. Unscrew the Nuts from the Tie Rods.

NOTE: The tie rods may release from the air motor base.

9. Remove the Air Motor Base from the Cylinder.
 - Push on the Piston Rod to ease disassembly.
10. Position the Air Motor Base bottom upward.

CAUTION

Use internal circlip pliers to remove Circlip (11). Tension on the Circlip requires the use of Truarc # 0700-10 or equivalent pliers for removal. Damage to component may occur.

11. Remove Circlip (11) from the air motor base.
12. Remove Washer (10), U-Cup Seal (9), Bearing (8), and Seal (7) from the air motor base.

Pump Tube

13. Remove the Lower Rod assembly from the bottom of Lower Tube (23).
14. Unscrew Nut (29) from the Lower Rod.

15. Remove Valve Plate (28), Spacer (27) from the Lower Rod.
16. Remove Lower Valve Seat (26), Support Ring (25), and U-Cup Seal (9) from the Lower Rod.
 - Remove the U-Cup Seal and the Support Ring from the Lower Valve Seat.
17. Remove Guide (24) from the Lower Rod.
18. Unscrew Upper Tube (17) from Lower Tube (23).
19. Remove O-Ring (16) from the Upper Tube.
20. Remove Valve Stop (18) from the Lower Tube.
21. Remove Check Valve (20) with U-Cup Seal (19) from the Lower Tube.
 - Remove the U-Cup Seal from the Check Valve.
22. Remove Upper Valve Seat (22) and O-Ring (21) from the Lower Tube.

Clean and Inspect

NOTE: Use the appropriate repair kit for replacement parts. Make sure all the components are included in the kit before discarding used parts.

1. Clean all metal parts in a modified petroleum-based solvent. The solvent should be environmentally safe.
2. Inspect all parts for wear and/or damage.
 - Replace as necessary.

EXAMPLE: Inspect O-Ring (12) for any nicks or cracks. Replace as necessary to ensure an airtight seal with the air motor base.

3. Inspect Lower Rod (15) closely. Use a magnifying glass to detect any score marks.
 - Replace as necessary.
4. Closely inspect the mating surfaces of both check valve components for any imperfections. Ensure a smooth and clean contact is obtained when assembled.

5. Inspect the lower portion of Guide (24) for grooves.
 - Replace as necessary.
6. Inspect Valve Stop (18) for signs of breakage.
 - Ensure the Valve Stop seats properly in the counterbore of Upper Tube (17).

Assembly

NOTE: Prior to assembly, certain components require lubrication in clean oil. Refer to Table 4 for details.

Pump Tube Upper Packing

NOTE: Refer to **Figure 4** for section view of the upper packing components.

1. Position the base of the air motor bottom upward.
2. Install and seat Seal (7) [heel end first] into the air motor base.
3. Install and seat Bearing (8) into the base.
4. Install and seat U-Cup Seal (9) [heel end first] into the base.
5. Install Washer (10) onto the U-Cup Seal.
6. Install and seat Circlip (11) into the groove.
 - Use the proper tool.
7. Lubricate the air motor piston rod with grease.

CAUTION

Make sure components are in alignment or damage to O-rings can occur.

8. Install the air motor base onto the air motor.
9. Screw the nuts onto the tie rods (or the tie rods into the base).
 - Tighten the nuts securely in an crisscross pattern.
10. Apply air pressure to the motor to ensure it cycles.
 - Refer to the **Air Motor Service Guide** for details.

Item No. on Figure 2-A	Description	Item No. on Figure 2-B	Description
7	Seal, 1-7/8 " ID x 2-3/8 " OD	9	Seal, U-Cup, 1-7/8 " ID x 2-1/2 " OD
9	Seal, U-Cup, 1-7/8 " ID x 2-1/2 " OD	12	O-Ring, 4 " ID x 4-3/8 " OD
		16	O-Ring, 2-9/16 " ID x 2-3/4 " OD
		19	Seal, U-Cup, 3/4 " ID x 1-1/4 " OD
		21	O-Ring, 2-7/16 " ID x 2-5/8 " OD

Table 4 Components Lubricated in Clean Oil

Pump Tube

11. Position Lower Valve Seat (26) [large diameter downward] on the bench.
12. Install and seat Support Ring (25) onto the Lower Valve Seat.
13. Install and seat U-Cup Seal (9) [heel first] onto the Lower Valve Seat.
14. Position Lower Rod (15) on the bench with the roll pin hole downward.
15. Install Guide (24) [flat side first] onto the Lower Rod.
16. Install the Lower Valve Seat assembly [lips first] onto the Lower Rod.
17. Install Spacer (27) and Valve Plate (28) [flat side first] onto the Lower Rod.
18. Install Nut (29) that secures the assembly to the Lower Rod.
 - Do not overtighten.
19. Position the Lower Rod assembly vertically with the Nut on the bench.
20. Install Lower Tube (23) [flared end first] onto the Lower Rod assembly.
 - Use care passing the U-Cup Seal.
21. Install and seat O-Ring (21) onto Upper Valve Seat (22).
22. Install and seat the Upper Valve Seat assembly [O-Ring upward] into the Lower Tube.
23. Install U-Cup Seal (19) [heel first] into Check Valve (20).
24. Install and seat the Check Valve assembly [Seal upward] onto the Lower Rod.
25. Install Valve Stop (18) onto the Lower Rod.
26. Screw Upper Tube (17) [short counterbore end] into the Lower Tube.
 - Do not tighten at this time.
27. Install O-Ring (16) onto the Upper Tube.

Attach Pump Tube to Air Motor

28. Push the Lower Rod assembly upward until the roll pin hole is exposed above the Upper Tube.

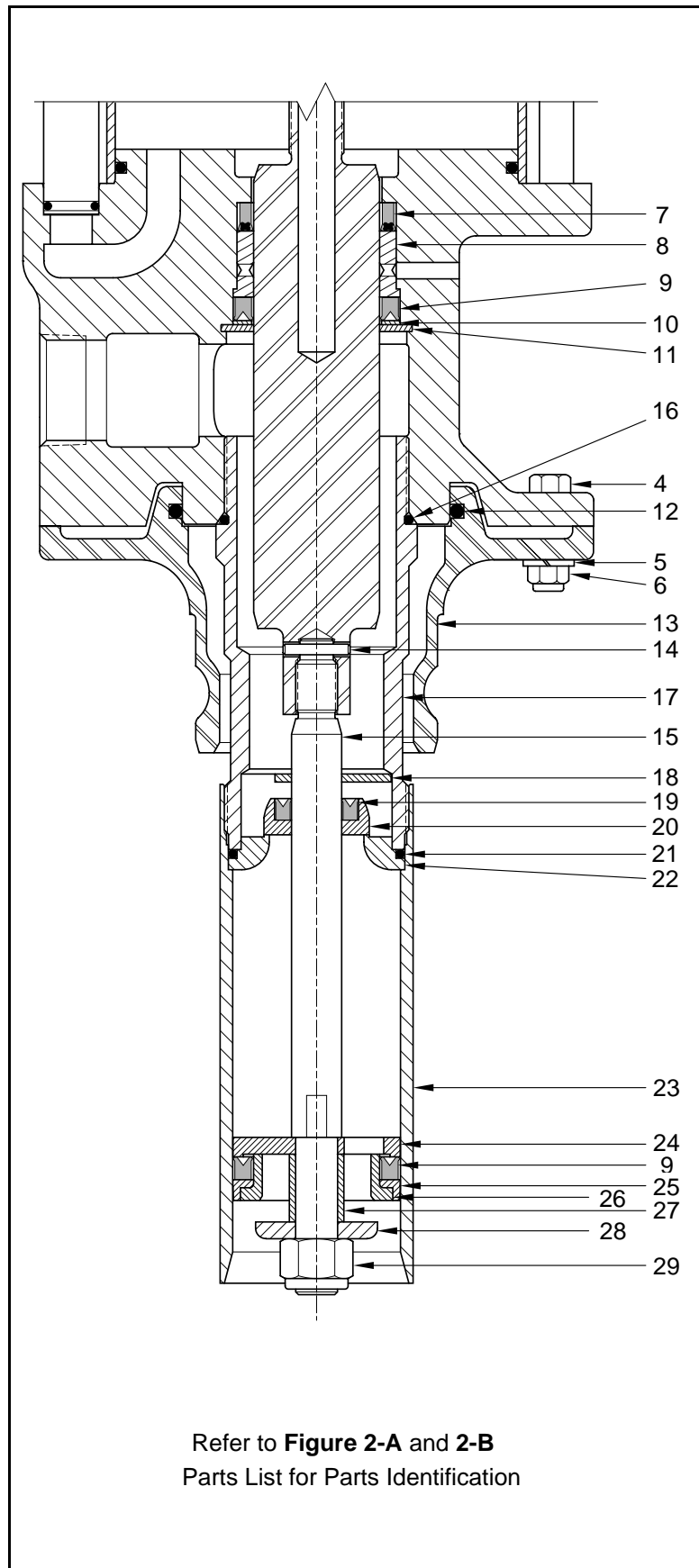

Refer to **Figure 2-A** and **2-B**
Parts List for Parts Identification

Figure 4 Pump Tube and Upper Packing Assembly
Section View

29. Screw the Lower Rod assembly into the piston rod until the roll pin holes align.
- Use a socket wrench.

CAUTION

Support the Lower Rod assembly and Piston Rod during Roll Pin (14) installation. Damage to components can occur.

30. Install Roll Pin (14).
- Use a small hammer.
31. Screw the Upper Tube into the air motor base.
- Use care passing the O-Ring.
32. Tighten the Lower Tube into the Upper Tube and at the same time the Upper Tube into the air motor base.
33. Install O-Ring (12) into Camlock Adapter (13).
- IMPORTANT: Lightly coat the inside diameter of the O-Ring with grease.*
34. Install the Camlock Adapter onto Air Motor Assembly (1).
- Use care when the O-Ring passes the air motor base.
35. Install Screws (4), Lockwashers (5), and Nuts (6) that secure the Camlock Adapter to the Air Motor Assembly.
- Tighten the Screws securely in a crisscross pattern.

Bench Test

1. Make sure air pressure at the regulator reads zero.
2. Install air Connector (2) to the inlet of the air motor.
3. Connect Air Coupler (3) to the Connector.
4. Slowly supply air pressure [not to exceed 20 psi (1.4 Bars)] to the pump's motor.
 - The pump assembly should cycle.

If the pump assembly does not cycle, refer to the **Troubleshooting Chart** for details.

With air pressure at zero:

5. Connect a product hose to the pump's material outlet.
 - Direct the hose into an appropriate collection container.
6. Place the pump in oil.
7. Slowly supply air pressure to the pump's motor.
8. Allow the pump to cycle slowly until the system and oil is free of air.

If the pump assembly does not prime, refer to the **Troubleshooting Chart** for details.

WARNING



Should leakage occur anywhere within the system, disconnect air to the motor. Personal injury can occur.

With air pressure at zero:

9. Attach a control valve to the outlet hose of the pump.
10. Set the air pressure to 100 psi (6.9 Bar).
11. Operate the control valve into a container.
12. Allow the pump to cycle until the system and oil is once again free of air.
13. Shut off the control valve.
 - Visually inspect the pump for external leaks.
 - The pump should not cycle. *

If the pump does not adequately stall, refer to the **Troubleshooting Chart** for details.

14. Check the motor for air leakage.

If the motor leaks, refer to the **Air Motor Service Guide** for details.

* A pump that does not completely stall with oil does not necessarily mean that it will not stall with grease.

Installation

These pumps connect to a female camlock which is part of a bulk container system. See **Figure 5** for a typical installation.

Additional items that should be incorporated into the air piping systems are listed in **Table 5**.

Part Number	Description
5612-2	Moisture Separator
SM7612-B	Regulator and Gauge
5912-2	Lubricator *

Table 5 Air Line Components

* Although the air motor is lubricated at the factory, the life of the motor can be extended with the use of a

lubricator.

Prove the Pump

Aerated product is due to external leakage; either at the pump or at the connection fittings on the bulk container. Isolation of the pump from the bulk container can help “prove the pump”.

1. Place the pump in oil.
2. Follow procedures 9 through 13 within the section entitled **Bench Test**.

If the pump does not leak externally * the fittings on the bulk container may not be sealing properly.

* The pump may still contain an air leak at

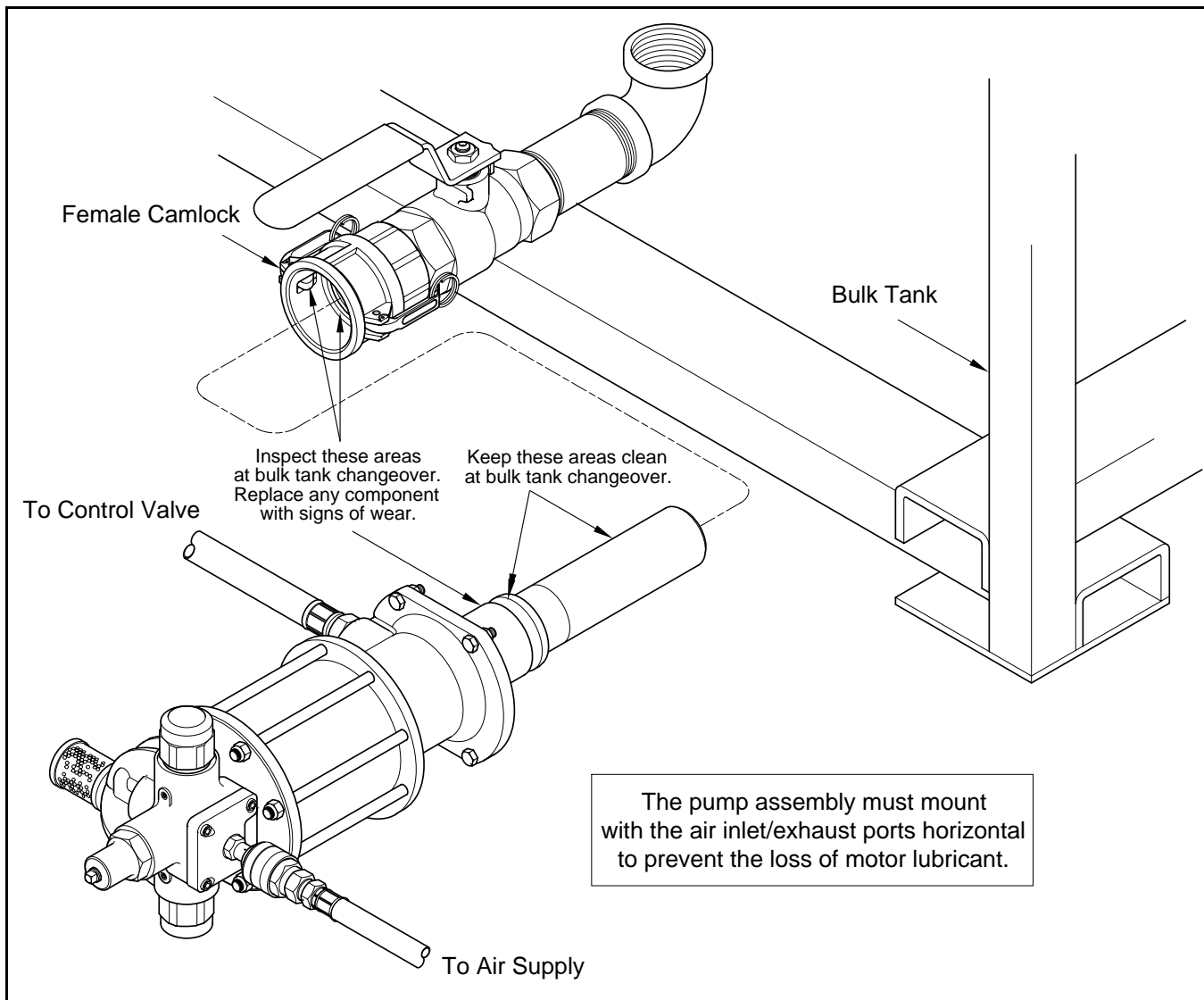

Troubleshooting Chart

Pump Indications	Possible Problems	Solution
Pump does not cycle	<ol style="list-style-type: none"> 1. Insufficient air pressure 2. Air motor not operating properly 3. Pump tube jammed and/or contains loose components 	<ol style="list-style-type: none"> 1. Increase air pressure 2. Inspect air motor and rebuild or replace as necessary 3. Rebuild pump tube
Pump will not prime	<ol style="list-style-type: none"> 1. Pump leaking internally 2. Improper seal between Camlock Adapter (14) and camlock 3. Bulk container connection fittings leaking 4. Pump leaking externally 	<ol style="list-style-type: none"> 1. See Internal Leaks 2. Replace seal in camlock 3. Seal fittings and tighten securely 4. See External Leaks
Product is aerated *	<ol style="list-style-type: none"> 1. Improper seal between Camlock Adapter (13) and camlock 2. Bulk container connection fittings leaking 3. Pump leaking externally 	<ol style="list-style-type: none"> 1. Replace seal in camlock 2. Seal fittings and tighten securely 3. See External Leaks
Pump cycles rapidly	Product source empty	Replenish product
Pump will not stall (cycles more than once or twice/hour)	<ol style="list-style-type: none"> 1. Pump leaking internally 2. Pump leaking externally 3. Distribution system leaking 	<ol style="list-style-type: none"> 1. See Internal Leaks 2. See External Leaks 3. Correct leak
External Leaks		
Product leakage from weep hole in air motor base	<ol style="list-style-type: none"> 1. Damaged upper U-Cup Seal (9) 2. Damaged air motor piston rod. 	<ol style="list-style-type: none"> 1. Separate pump tube from air motor and replace upper U-Cup Seal (9) 2. Inspect piston rod and replace as necessary
Product leakage at Upper Tube (23)	<ol style="list-style-type: none"> 1. Pump tube not sufficiently tight 2. Damaged O-Ring (16) 	<ol style="list-style-type: none"> 1. Tighten pump tube assembly 2. Separate pump tube from air motor and replace O-Ring (16)
Air leakage from weep hole in air motor base	Damaged Seal (7)	Separate pump tube from air motor and replace Seal (7)
Product leakage visible between Upper Tube (17) and Lower Tube (23)	<ol style="list-style-type: none"> 1. Pump tube not sufficiently tight 2. Damaged O-Ring (21) 	<ol style="list-style-type: none"> 1. Tighten pump tube assembly 2. Separate Upper Tube (18) from Lower Tube (23) and replace O-Ring (21)
Pump will not prime or product is aerated *	Damaged O-Ring (12)	Remove Camlock Adapter (13) and replace O-Ring (12)
Internal Leaks		
Pump will not prime or pump will not stall (cycles more than once or twice/hour)	<ol style="list-style-type: none"> 1. Foreign material between Check Valve (20) and Upper Valve Seat (22) 2. Foreign material between Lower Valve Seat (26) and Valve Plate (28) 3. Worn or damaged Check Valve (20) 4. Worn or damaged Upper Valve Seat (22) 5. Worn or damaged Lower Valve Seat (26) 6. Worn or damaged Valve Plate (28) 7. Worn or damaged U-Cup Seal (19) 8. Worn or damaged Lower Rod (15) 9. Worn or damaged lower U-Cup Seal (9) 10. Worn or damaged Lower Tube (23) 	<p>Locate and eliminate source of foreign material.</p> <p>Disassemble pump tube, clean, inspect and replace worn or damaged components.</p>
* Should the pump aerate product, see Section entitled Prove the Pump for details.		

Changes Since Last Printing
 Removed Part Number 323842

