

**DESCRIPTION**

Model 7783 Series Pumps are single-action, low pressure units designed to deliver fluid lubricants from original containers or bulk tanks.

The differences in the pumps are that model 7783-A4 is used with 55-gallon drums, model 7783-B4 is used with 16-gallon drums and model 7783-C4 is a stub pump and can be used with extensions.

All models produce a 6:1 material-to-air pressure ratio. The maximum operating air pressure of 200 psi would, therefore, create a maximum material pressure of 1200 psi.

The pumps are capable of supplying a high volume of lubricant at a low rate of speed (e.g.—At 100 psi air pressure, the pump delivers 10 gallons of SAE No. 140 gear oil per minute).

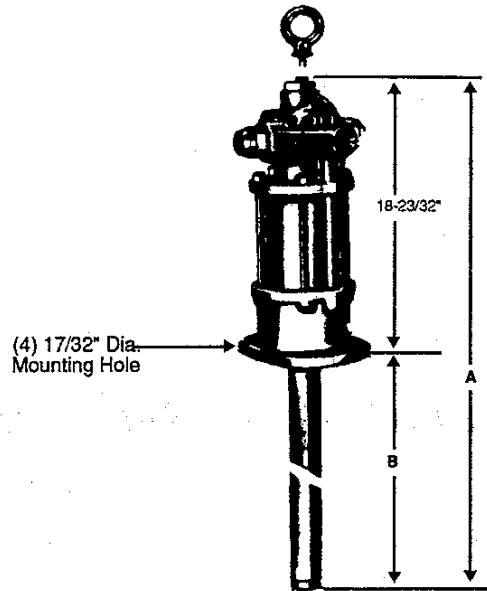

*Figure 1: Series 7783 Low-Pressure Pump*

**NOTE:** The air motor (323440-4) is packed with lubricant at the factory and should require no additional lubrication.

**SPECIFICATIONS****PUMP:**

Ratio ..... 6:1  
 Recommended Operating Air Pressure ..... 50-175 psi  
 Maximum Operating Air Pressure ..... 200 psi  
 Maximum Operating Material Pressure ..... 1200 psi  
 Displacement ..... 9.8 cu. in./cycle  
 Weight (basic pump, approx.) ..... 50 lbs.  
 Dimensions (Figure 1):

"A" (Model 7783-A4) ..... 51-23/32"  
 (Model 7783-B4) ..... 44-7/32"  
 (Model 7783-C4) ..... 32-1/8"  
 "B" (Model 7783-A4) ..... 33"  
 (Model 7783-B4) ..... 25-1/2"  
 (Model 7783-C4) ..... 13-13/22"

**AIR MOTOR:**

Air Inlet ..... 3/4" NPTF  
 Air Outlet ..... 3/4" NPTF  
 Material Outlet ..... 1/2" NPTF  
 Piston Diameter ..... 4-1/4"  
 Stroke ..... 4"

**GENERAL SAFETY REQUIREMENTS**

Because these units are incorporated into pressure pumping systems, it is good practice to observe and use the following safety precautions:

1. Do not exceed the pressure rating of any component in the system.
2. Protect all material and air supply lines from damage or puncture.

FOR FURTHER SERVICE, CONTACT YOUR LOCAL ALEMITE DISTRIBUTION CENTER



**ALEMITE CORPORATION**  
**4701 PARK RD CHARLOTTE NC 28209-9967**

### List of Accessories

Name of Item	Part No.
Cover Assembly for 120-pound Drums	323800-4
Cover Assembly for 400-pound Drums	323847-4
Bung Adapter	326750-B1
Low-Level Cut Off Switch (7783-C4 only)	321206
Extension Tube (7783-C4 only)	337123-1

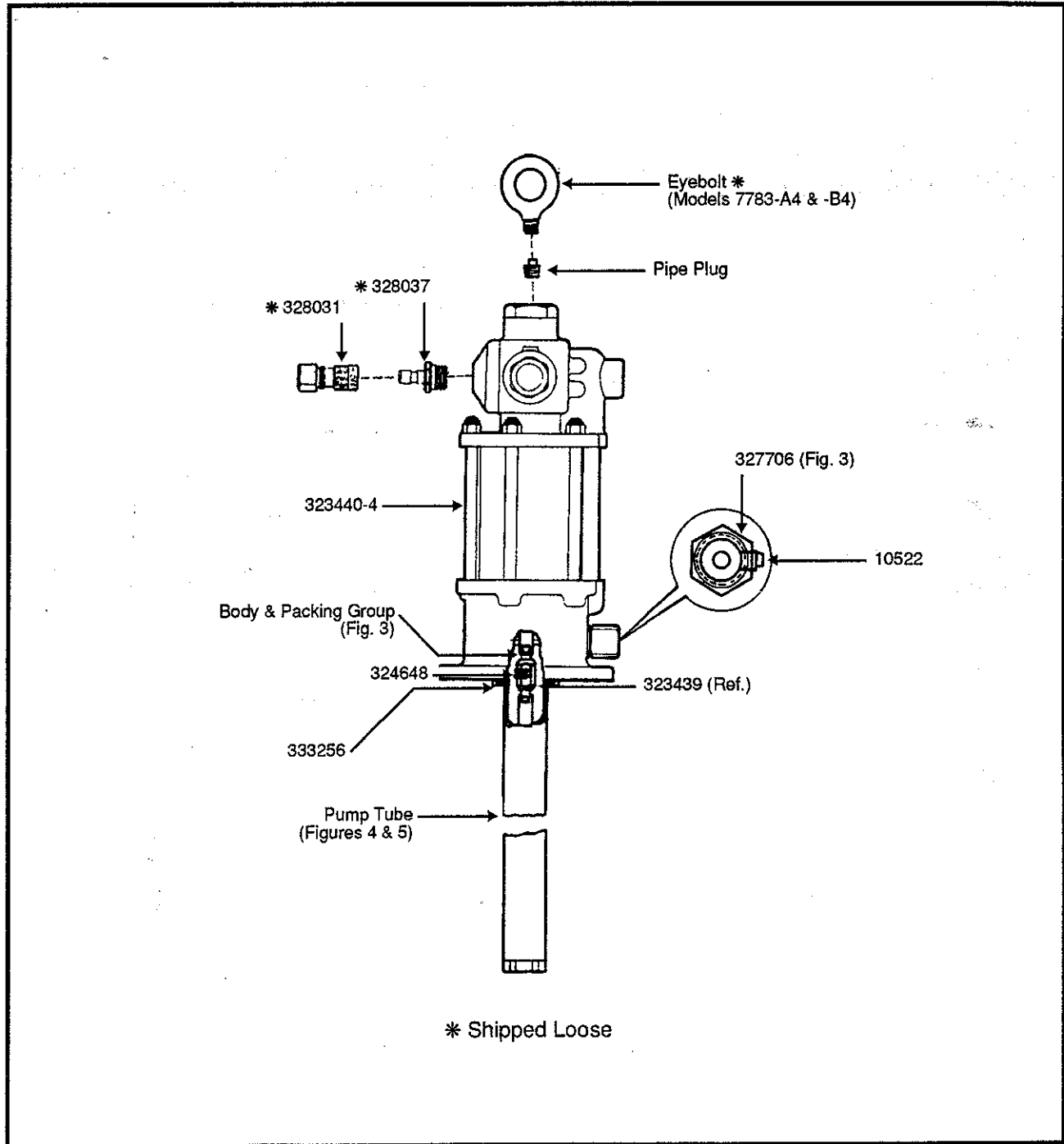

Figure 2: Components of Series 7783 Low-Pressure Fluid-Lubricant Pumps

3. Check all hoses for weak or worn conditions prior to daily work operations, making certain that all connections and fittings are secure.

4. Never point dispensing device at oneself or at any other person: accidental discharge of pressure will result in serious injury.

5. Release all pressures within the system before attempting to remove or service any components in the system.

6. Be sure to read all instructions and any other explanatory material carefully and thoroughly, before attempting to assemble, disassemble, or operate the system.

### INSTALLATION

**NOTE:** Remove all shipping seals from air motor 323440-4 and pump tube assembly.

1. Thread male adapter 328037 into 3/4" air inlet of air motor (Figure 2).

2. Thread air coupler 328031 onto facility air hose.

3. If unit is equipped with eyebolt, remove pipe plug from top of air motor and replace with eyebolt (Figure 2).

4. If unit is to be used with an optional cover assembly, perform the following steps:

**NOTE:** It may be desirable to lift pump (by eyelet) with a hoist for ease in installing cover assembly onto pump.

a. Slide cover over pump tube and align four (4) holes of cover with holes on underside of air motor assembly.

b. Secure cover using four (4) stop nuts and four (4) screws (supplied).

c. Install three (3) thumb screws into openings on side of cover.

5. Install and secure pump into drum, tank, or suction pipe.

6. Connect material hose (not supplied) to 1/2" material outlet of air motor assembly.

7. Connect air coupler 328031 of facility air hose to male adapter 328037 in air motor assembly.

### OPERATION

**CAUTION:** If dispensing device is used with the system, never point it at oneself or any other person. Accidental discharge of material may result in serious injury.

1. Check entire system (fittings, hoses, connections, etc.) for leaks or signs of wear.

**IMPORTANT:** Extra care should be taken to protect material lines from damage or wear. Do not kick hose or place near sharp moving objects. **ACCIDENTAL DISCHARGE OF MATERIAL MAY RESULT IN SERIOUS INJURY.**

2. Gradually turn on air supply while checking for leaks in the system.

3. Adjust air pressure to receive desired material pressure.

**NOTE:** The use of an air regulator (not supplied) is recommended to determine and control air pressure.

**CAUTION:** Maximum operational air pressure is 200 psi. **DO NOT** exceed this limit.

4. If no leaks are present and system stalls out, system is now ready for use.

**CAUTION:** **DO NOT** operate unit if condition of any parts are in question.

### MAINTENANCE

Do the following periodically:

1. Check for any damage to material or air supply lines.

2. Check all connections and fittings for tightness.

3. Check level of material in drum.

**NOTE:** Do not allow pump to run "dry" at any time.

### SERVICE DIAGNOSIS

If pump fails to function properly, check the following:

1. Inadequate air pressure.

2. Insufficient amount of material in drum.

3. Foreign material lodged in check valve.

4. Worn packings in pump tube.
5. Worn or damaged parts in pump tube.
6. Worn or damaged parts in air motor.

**SERVICE**

**CAUTION:** Before beginning service or attempting to disassemble any part of unit, shut off air supply, reduce material pressure to zero, disconnect air and material supply lines, and remove entire pump from container or system.

**IMPORTANT:** Prior to reassembly, lubricate all "O" rings, seals and packings with SAE No. 10 oil or light machine oil. Protect all seals and sealing surfaces from damage and scratches in any way possible.

**DISASSEMBLY:**

**A. SEPARATING PUMP TUBE FROM AIR MOTOR:**  
(Figure 2)

1. Loosen jam nut 333256 securing pump tube to air motor assembly 323440-4.
2. Unthread pump tube assembly from air motor assembly and pull to expose coupling 323439.
3. Remove upper spring clip 324648 from coupling.
4. Unthread coupling from air motor piston rod by rotating entire pump tube assembly.

**B. SERVICING AIR MOTOR ASSEMBLY:**

To service the 323440-4 Air Motor Assembly, refer to Instruction Sheet SER 323440-4.

**C. SERVICING BODY & PACKING GROUP:**  
(Figure 3)

1. Unscrew and remove adapter 327706 from body of air motor assembly 323440-4 (Figure 2).
2. Remove washer 323419 and bushing 324274 from adapter.
3. Unscrew three screws 323787 and pull body 323786 from air motor assembly.
4. Remove "O" rings 171009-33 and 171009-35 from body.
5. From bottom of body, remove gasket 323693, washer 332465, second gasket 323693 and spacer 332466.

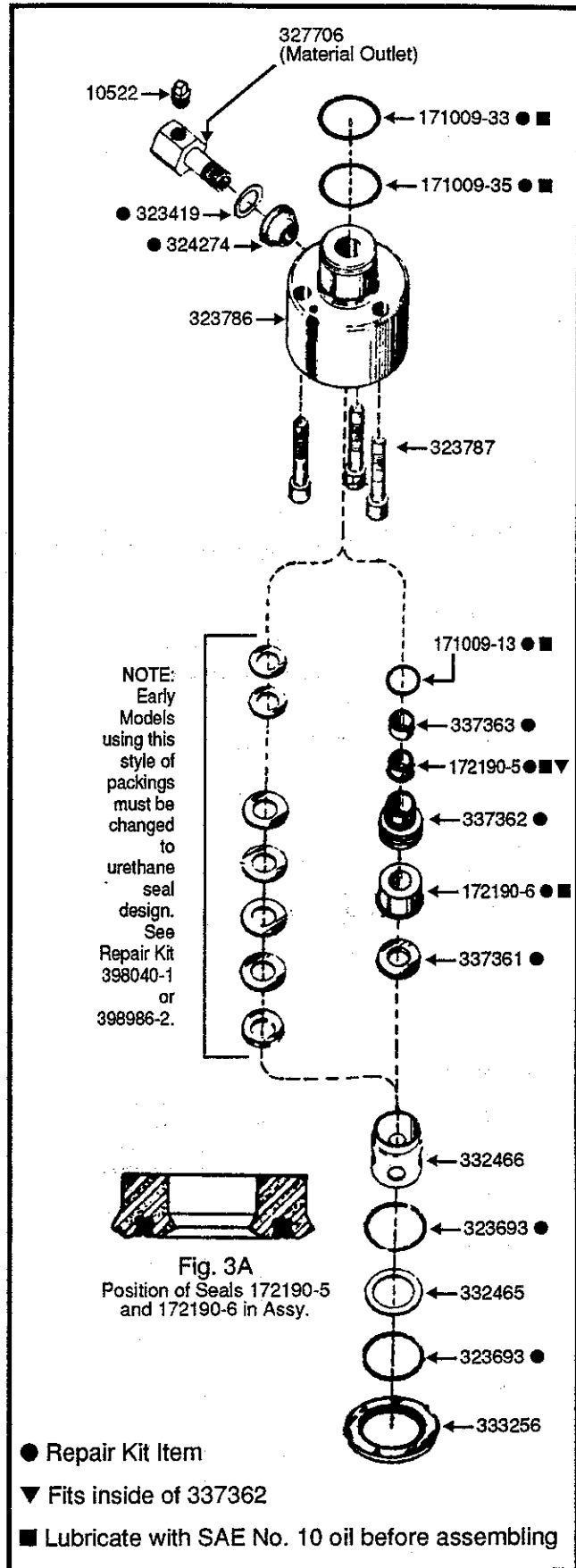

**Figure 3: Body and Packing Group**

6. Early Models:

Remove the bearing, four packings, the lantern ring, two packings and block "V" packing through the bottom of body.

**NOTE:** Early models using this old style of packings must be changed to the urethane seal design in repair kits 393040-1 or 398986-2.

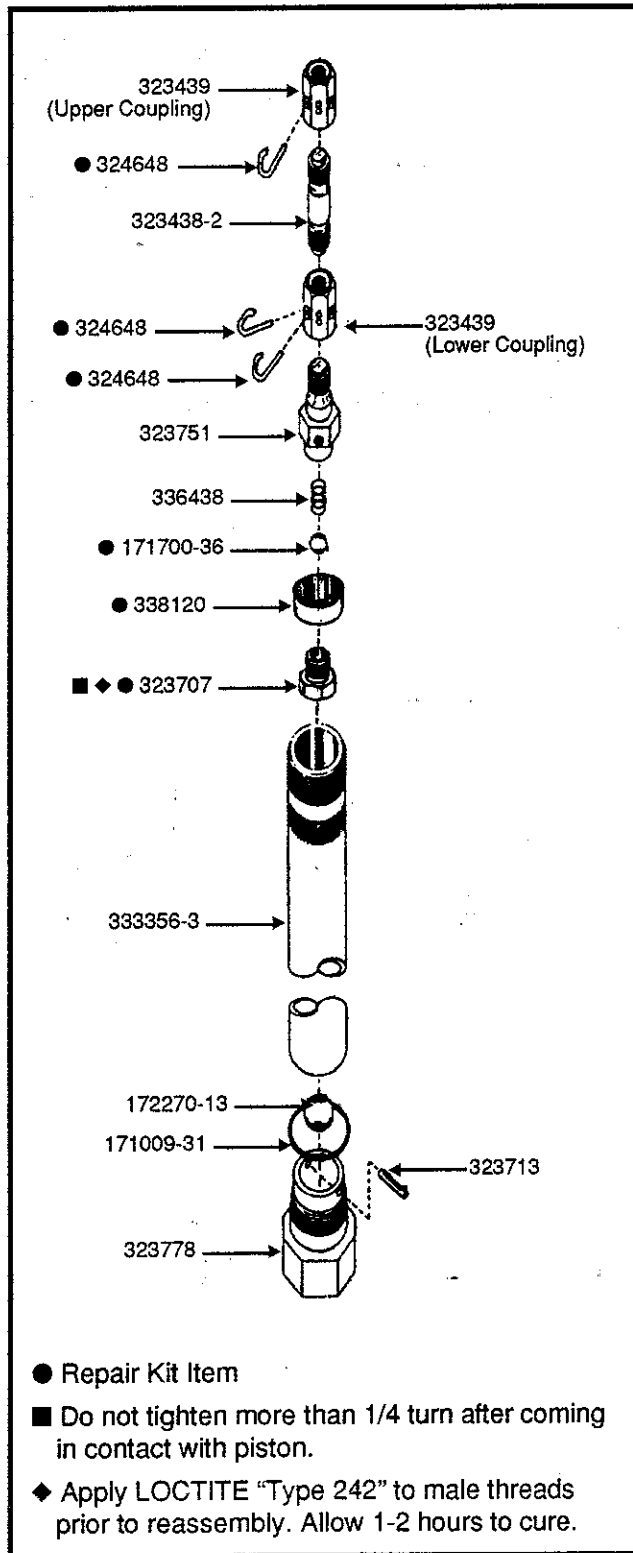

Figure 4: Pump-Tube Assembly for Model 7783-C4

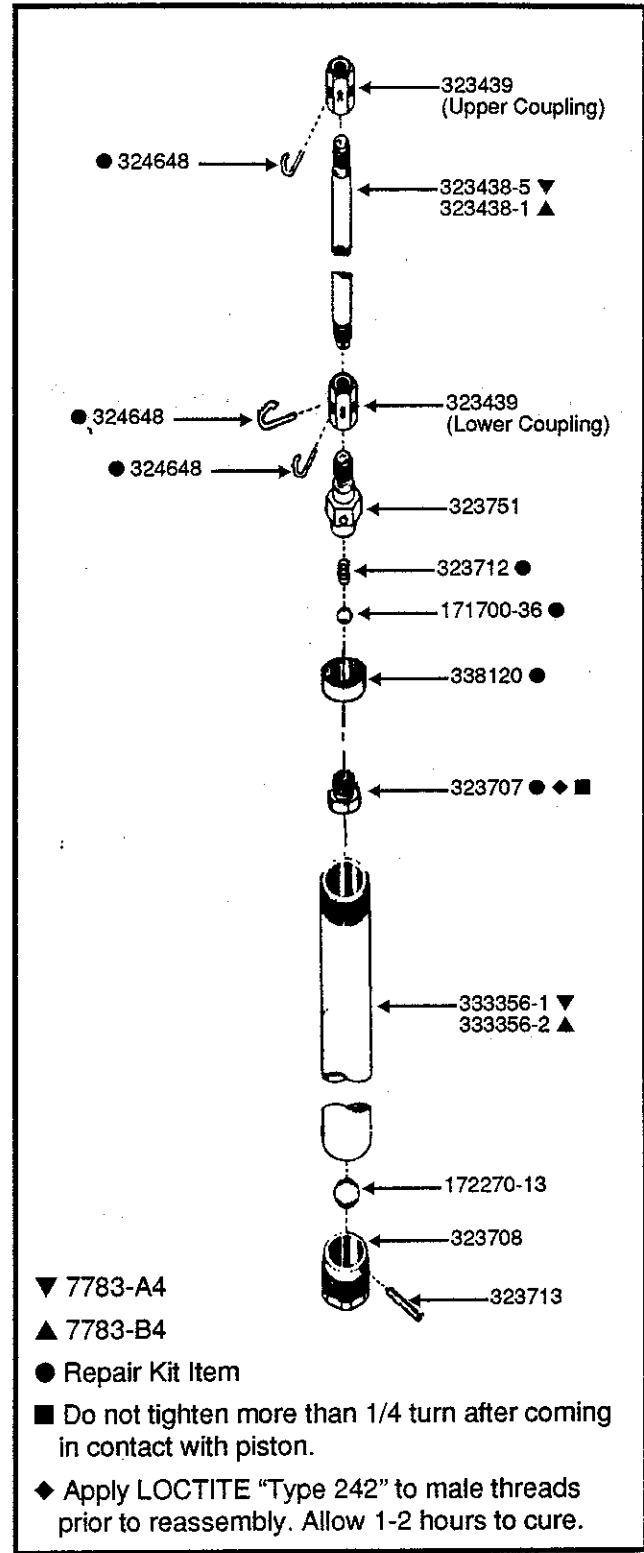

Figure 5: Pump-Tube Assembly for Models 7783-A4 & 7783-B4

Later Models:

Remove washer 337361, seal 172190-6, lantern ring 337362, seal 172190-5, spacer 337363, and "O" ring 171009-13 through bottom of body.

**NOTE:** At reassembly, lips of seals 172190-5 and 172190-6 must face downward as shown in Figure 3A.

7. Clean and inspect all parts for wear and damage.
8. Reassemble by reversing the above steps.

**D. SERVICING PUMP TUBE ASSEMBLY:**  
(Figures 4 & 5)

1. If you have not already done so, disconnect pump tube from air motor as previously described in "SEPARATING PUMP TUBE FROM AIR MOTOR" section of SERVICE.

2. Grab upper coupling 323439 and pull upward until contents of pump tube is removed from cylinder 333356-1, 333356-2 (Figure 5) or 333356-3 (Figure 4).

3. Remove lower spring clip 324648 from upper coupling 323439. Unthread and remove upper coupling from rod 323438-2 (Figure 4), 323438-1 or 323438-5 (Figure 5).

4. Remove two spring clips 324648 from lower coupling 323439. Unthread and remove rod from lower coupling, then remove lower coupling from adapter 323751.

5. Unthread and remove valve seat 323707 from adapter 323751. Remove piston 338120, ball 171700-36, and spring 336438 (Figure 4) or 323712 (Figure 5).

**NOTE:** At reassembly, apply LOCTITE "Type 242" to male threads of valve seat 323707 prior to installation. Do not tighten more than 1/4 turn after coming in contact with piston 338120. Allow 1-2 hours to cure.

6. Gripping foot valve body 323778 (Figure 4) or 323708 (Figure 5), unthread cylinder from foot valve body.

7. Model 7783-C4 only.

Remove "O" ring 171009-31 from foot valve body (Figure 4).

8. Tap out pin 323713 from foot valve body and remove ball 1722703-13.

9. Clean and inspect all parts for wear or damage.

**IMPORTANT:** Worn or damaged parts present a threat to personnel and property. NEVER reuse worn or damaged parts.

**REASSEMBLY:**

Reassemble each section by reversing steps used to disassemble and observe the accompanying notes.

## Major Repair Kits

**\* 398986-2 For Series 7783 Pump-Tube Assemblies**

Part No.	Figure	Description	Qty.
171009-13	3	"O" Ring, 1-3/16" I.D. x 1-5/16" O.D.	1
171009-31	4	"O" Ring, 1-11/16" I.D. x 1-7/8" O.D. (Model 7783-C4)	1
171009-33	3	"O" Ring, 1-3/16" I.D. x 2" O.D.	1
171009-35	3	"O" Ring, 1-15/16" I.D. x 2-1/8" O.D.	1
171700-36	4, 5	Ball, 9/16" Diameter	1
■ 172190-5	3	Seal, 1-1/16" O.D. and 1/4" thick	1
■ 172190-6	3	Seal, 1-9/16" O.D. x 3/8" thick	1
323419	3	Washer, 7/8" I.D. x 1-19/64" O.D.	1
323693	3	Aluminum Gasket, 1-29/32" O.D.	2
323707	4, 5	Valve Seat	1
323712	5	Heavy Spring, 15/32" dia. x 27/32" long (7783-A4 & B4)	1
324274	3	Bushing	1
324648	4, 5	Spring Clip	4
336438	4	Light Spring, 15/32" dia. x 49/64" long (Model 7783-C4)	1
337361	3	Washer, 1-35/64" O.D.	1
337362	3	Lantern Ring	1
337363	3	Spacer	1
338120	4,5	Piston	1

\* This kit is used for repairing the pump-tube assemblies in 7783-A4, 7783-B4 and 7783-C4. The parts that are used for a specific pump tube are noted in the kits list.

■ These two parts can be purchased separately in packs of five for minor repairs. Order replacement-seal kit 393530-5 (Five each of 172190-5) or 393530-6 (Five each of 172190-6).

**393040-1 For Body and Seal Group (Figure 3)**

Part No.	Description	Qty.
171009-13	"O" Ring, 1-3/16" I.D. x 1-5/16" O.D.	1
171009-33	"O" Ring, 1-3/16" I.D. x 2" O.D.	1
171009-35	"O" Ring, 1-15/16" I.D. x 2-1/8" O.D.	1
■ 172190-5	Seal, 1-1/16" O.D. and 1/4" thick	1
■ 172190-6	Seal, 1-9/16" O.D. x 3/8" thick	1
323419	Washer, 7/8" I.D. x 1-19/64" O.D.	1
323693	Aluminum Gasket, 1-29/32" O.D.	2
337361	Washer, 1-35/64" O.D.	1
337362	Lantern Ring	1
337363	Spacer	1

■ See note in Kit 398986-2.

### PARTS LIST - 7783 Series Lubricant Pumps (Figure 2)

Part No.	Description	Qty.
■ + 323440-4	Air-Motor Assembly .....	1
323842	Eyebolt (7783-A4 and 7783-B4) .....	1
● 324648	Spring Clip .....	1
328031	Air Coupler (Female) .....	1
328037	Male Adapter .....	1
333256	Jam Nut, 2-16 UN .....	1
* +	Body and Packing Group (Figure 3) .....	1
* +	Pump-Tube Assembly (Figure 4 or 5) .....	1

- Repair Kit Part
- \* See separate parts list.
- See parts list in SER 323440-4
- + Not available as a separate purchased part.

### PARTS LIST - Body and Packing Group (Figure 3)

Part No.	Description	Qty.
10522	Pipe Plug .....	1
● 171009-13	"O" Ring, 1-3/16" I.D. x 1-5/16" O.D. ....	1
● 171009-33	"O" Ring, 1-13/16" I.D. x 2" O.D. ....	1
● 171009-35	"O" Ring, 1-15/16" I.D. x 2-1/8" O.D. ....	1
● ▼ 172190-5	Seal, 1-1/16" O.D. and 1/4" thick .....	1
● ▼ 172190-6	Seal, 1-9/16" O.D. x 3/8" thick .....	1
● 323419	Washer, 7/8" I.D. x 1-19/64" O.D. ....	1
● 323693	Aluminum Gasket, 1-29/32" O.D. ....	2
323786	Body .....	1
323787	Hex-Head Cap Screw, 1/2-13 (Special) .....	3
● 324274	Bushing .....	1
327706	Adapter .....	1
332465	Steel Washer, 1-9/16" I.D. x 1-15/16" O.D. ....	1
332466	Spacer .....	1
● 337361	Washer, 1-35/64" O.D. ....	1
● 337362	Lantern Ring .....	1
● 337363	Spacer .....	1

- Repair Kit Part
- ▼ Order 393530-5 (Pack of 5)
- ▲ Order 393530-6 (Pack of 5)

**PARTS LIST - Pump Tube Assembly (Model 7783-C4, Figure 4)**

Part No.	Description	Qty.
● 171009-31	"O" Ring, 1-11/16" I.D. x 1-7/8" O.D.	1
● 171700-36	Ball, 9/16" Diameter	1
172270-13	Ball, 1-1/16" Diameter	1
323438-2	Rod	1
323439	Coupling	2
● 323707	Valve Seat	1
323713	Pin	1
323751	Adapter	1
323778	Foot-Valve Body	1
● 324648	Spring Clip	3
333356-3	Cylinder	1
● 336438	Light Spring, 15/32" dia. x 49/64" long	1
● 338120	Piston	1
●	Repair Kit Part	

**PARTS LIST - Pump Tube Assembly (Models 7783-A4 and 7783-B4, Figure 5)**

Part No.	Description	Qty.
● 171700-36	Ball, 9/16" Diameter	1
172270-13	Ball, 1-1/16" Diameter	1
▲ 323438-1	Rod	1
▼ 323438-5	Rod	1
323439	Coupling	2
● 323707	Valve Seat	1
323708	Foot-Valve Body	1
● 323712	Heavy Spring, 15/32" dia. x 27/32" long	1
323713	Pin	1
323751	Adapter	1
● 324648	Spring Clip	3
▼ 333356-1	Cylinder	1
▲ 333356-2	Cylinder	1
● 338120	Piston	1
●	Repair Kit Part	
▼	7783-A4	
▲	7783-B4	

**NOTE:** The parts listed in this instruction sheet are for reference identification in the instructions and illustrations. Some of them are not available as separate parts and these are noted in the parts list. Standard items such as nuts, bolts, etc. should be purchased at a hardware store. Refer to the current parts price list and bulletins before ordering parts, and always give the part number, quantity, description and model where used when ordering parts. Parts availability and prices are subject to change without notice.

**PARTS CHANGES SINCE LAST PRINTING**

Deleted: 18181, 327123-1, 332824