

Portable Hand-Operated Pump

Description

The major components of the portable pump assembly in the 8571 model series consist of a(n):

- hand-operated reciprocating pump
- drum cover assembly
- drum dolly assembly
- delivery hose with fluid filter and manual non-drip nozzle assembly
- electronic meter

Pump

The low-pressure pump included with the assembly is designed to dispense automatic transmission fluid directly from their original 16-gallon containers.

The pump delivers approximately 1 quart (0.95 liter) of product in six cycles [2-strokes per cycle - one upward and one downward].

Models 8571-5 and 8571-A5

The electronic meter on each model registers in a different unit of measurement. See **Figure 1**.

Model Assembly

Refer to **Figure 2** for details on the assembly of all packaged components.

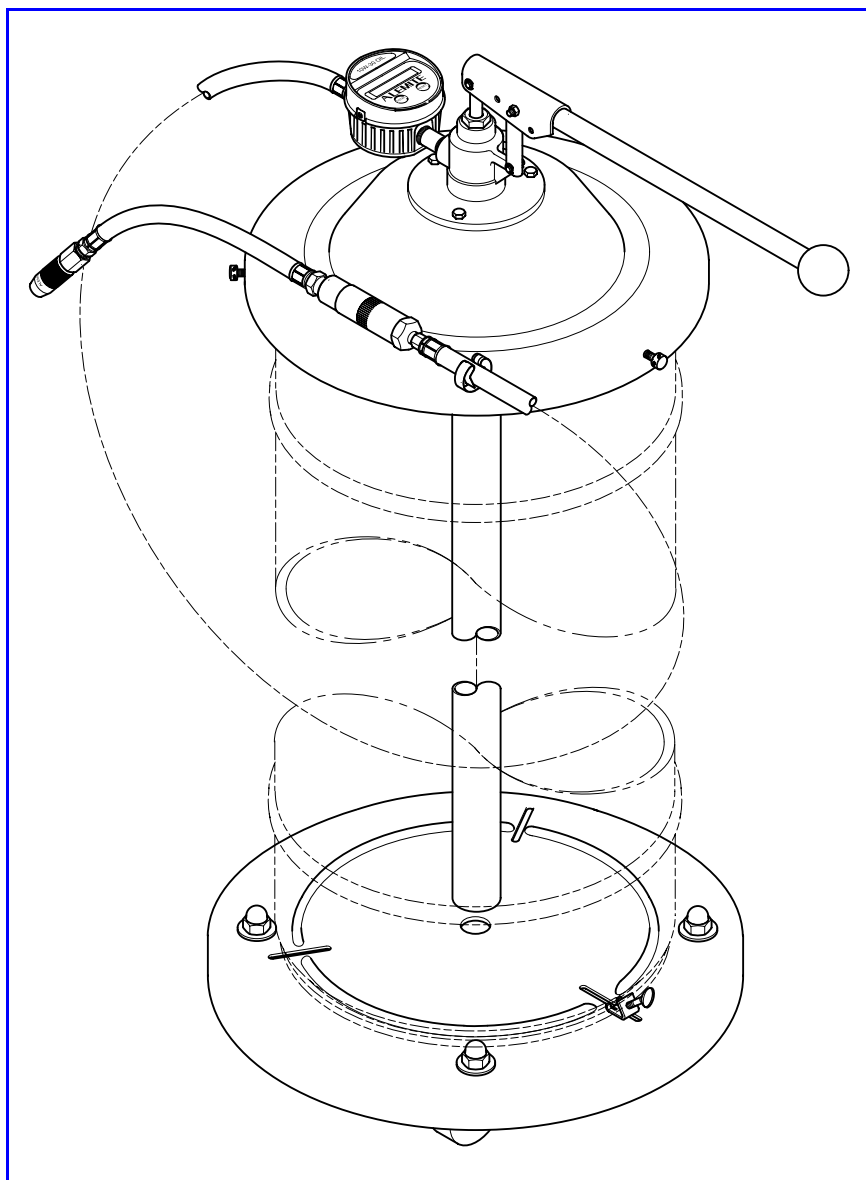

Pump Model	Meter Register	Model Weight		Overall Height (including Drum)	
		lbs	kg	Inches	Meter
8571-5	Quarts	35	15.9	39-3/8	1
8571-A5	Liters				

Figure 1 Portable Hand-Operated Pump Models 8571-5 and 8571-A5

Alemite Corporation
167 Rowland Drive, Johnson City, Tennessee 37601
www.alemite.com

Copyright © 2003 by Alemite Corporation

This document contains confidential information that is the property of Alemite Corporation and is not to be copied, used, or disclosed to others without express written permission.

SER 8571-5
Revision 12-03

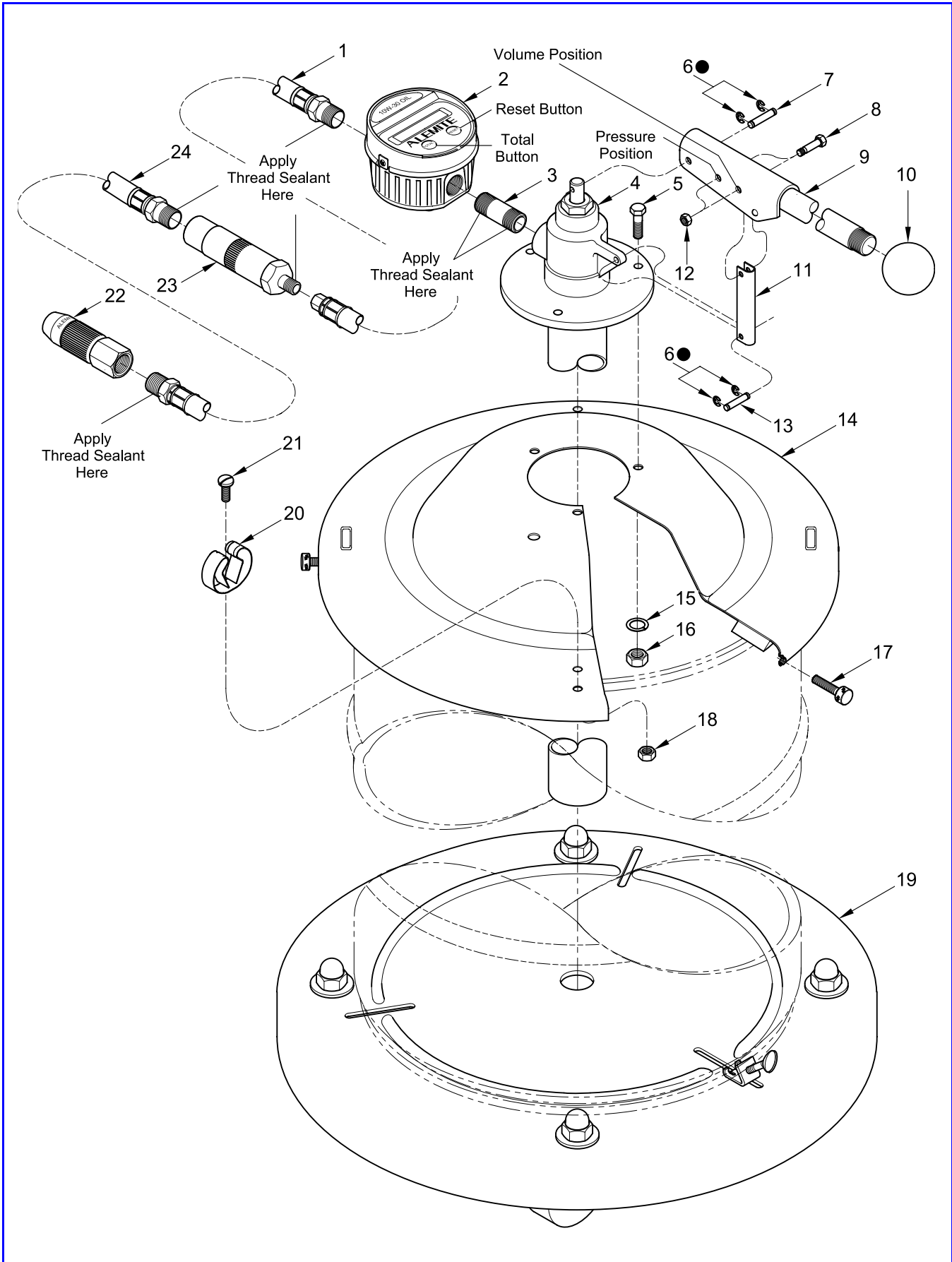

Figure 2 Portable Hand-Operated Pump Model 8571 Series - Exploded View

Item No.	Part No.	Description	Qty	Notes	Numeric Order Part # (Item #)
1	317809-5F	Hose, Material, 1/2 " ID (5-1/2 ' Long)	1		3630-A (2)
2	3630	Meter, Electronic (Quarts) <i>Model 8571-5</i>	1	See SER 3630	3630 (2)
	3630-A	Meter, Electronic (Liters) <i>Model 8571-A5</i>	1		48018 (17)
3		Nipple, 1/2 " NPT x 2 " Long	1		77650 (16)
4		Tube Assembly, Pump	1	See Figure 3	77787 (5)
5		Capscrew, 1/4 " -28 x 1-1/8 "	3		77903 (18)
6		Ring, Retaining	4	●	170276 (21)
7	339961-2	Pin	1		171606 (6)
8		Screw, 10-32 x 1-11/32 "	1		172207-1 (15)
9	324726	Bracket and Lever Assembly	1		172263-4 (3)
10	381901	Knob	1		309612 (20)
11	324741	Link	1		316315-5 (19)
12		Nut, Elastic Stop, 10-32	1		317809-5F (1)
13	339961-1	Pin	1		317860-1 (24)
14	328245-4	Cover Assembly (w/ Gasket)	1		321203 (23)
15		Washer, Lock, 1/4 "	3		324726 (9)
16		Nut, 1/4 " -20	3		324742 (8)
17	48018	Screw, Thumb, 1/4 " -28	3		324741 (11)
18		Nut, 8-32	1		328245-4 (14)
19	316315-5	Dolly Assembly	1	See SER 316315-5	328255-C4 (4)
20	309612	Clip, Spring	1		339084 (22)
21		Screw, 8-32 x 5/16 "	1		381901 (10)
22	339084	Nozzle Assembly, Non-Drip Manual	1		339961-1 (13)
23	321203	Filter Assembly, Fluid	1	See Figure 4	339961-2 (7)
24	317860-1	Hose, Material, 1/4 " ID (1 ' Long)	1		401514 (12)

Legend:
 Part numbers left blank (or in *italics*) are not available separately
 ● designates a repair kit item

Repair Kit

Part No.	Kit Symbol	Description
394261-1	●	Kit, Repair (Includes items on Figure 2 and Figure 3)

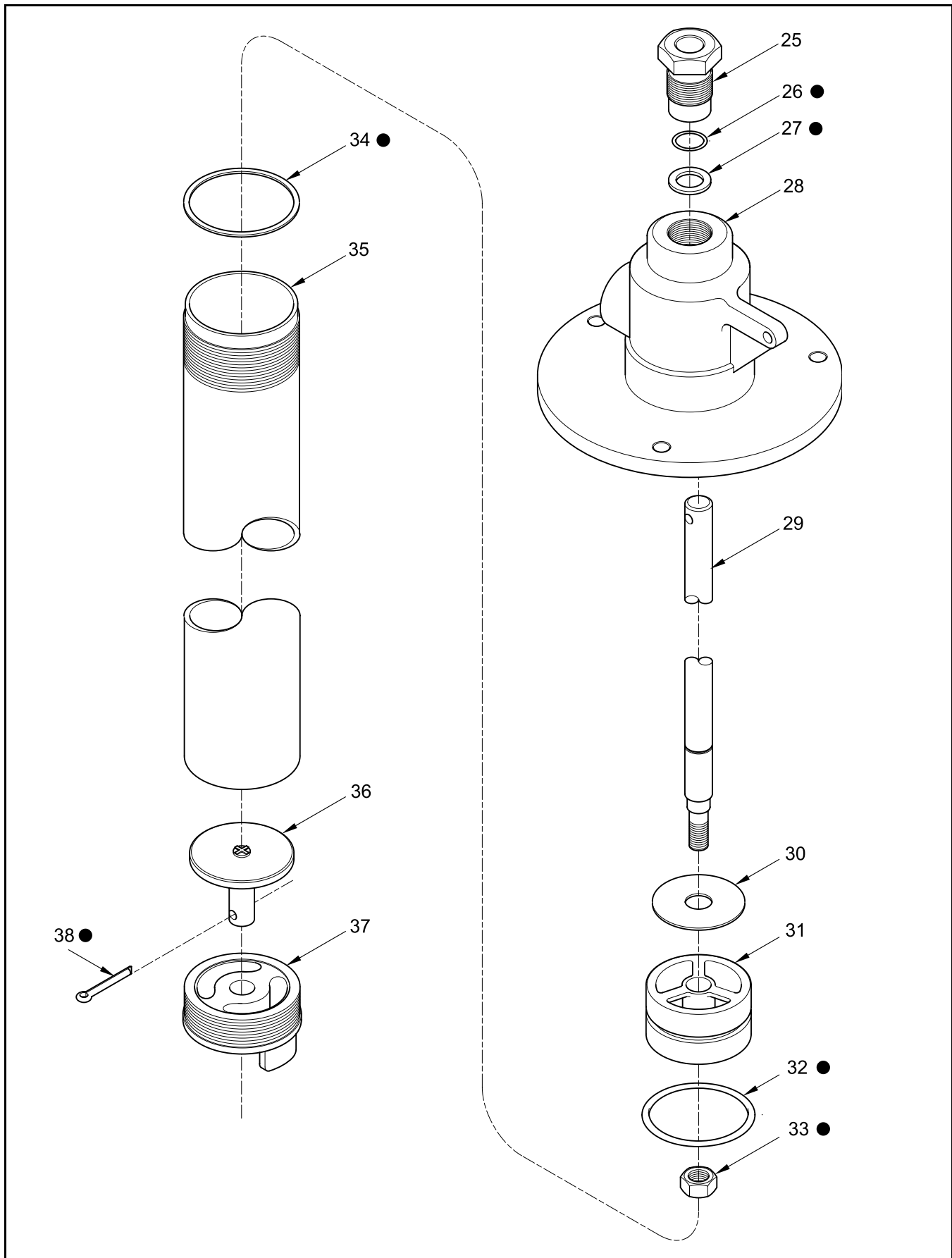

Figure 3 Pump Tube Assembly for Model 8571 Series - Exploded View

Item No.	Part No.	Description	Qty	Notes	Numeric Order Part # (Item #)
25	324733	Nut, Packing	1		<i>17070</i> (33)
26		O-Ring, 1/2 " ID x 5/8 " OD	1	●	50712 (37)
27		Gasket	1	●	131315 (36)
28	328254-4	Body, Outlet	1		<i>131472</i> (34)
29	328257-5	Rod	1		<i>171001-23</i> (32)
30	324747	Valve, Upper	1		<i>171009-2</i> (26)
31		Body, Plunger	1		<i>172212-14</i> (38)
32		O-Ring, 1-1/4 " ID x 1-1/2 " OD	1	●	<i>319320</i> (31)
33		Nut, Elastic Stop, 5/16 " -18	1	●	324733 (25)
34		Gasket	1	●	324747 (30)
35	328256-3	Tube	1		<i>326784</i> (27)
36	131315	Valve, Foot	1		328254-4 (28)
37	50712	Body, Foot Valve	1		328256-3 (35)
38		Pin, Cotter, 3/32 " x 5/8 " Long	1	●	328257-5 (29)
Legend: Part numbers left blank (or in <i>italics</i>) are not available separately ● designates a repair kit item					

Repair Kit

Part No.	Kit Symbol	Description
394261-1	●	Kit, Repair (Includes items on Figure 3 and Figure 2)

Overhaul

Prior to performing any maintenance procedure, the following safety precautions must be observed. Personal injury may occur.



WARNING

Do not use halogenated hydrocarbon solvents such as methylene chloride or 1,1,1-trichloroethane in this pump. An explosion can result within an enclosed device capable of containing pressure when aluminum and/or zinc-plated parts come in contact with halogenated hydrocarbon solvents.

Never point a nozzle at any portion of your body or another person. Accidental discharge of pressure and/or material can result in injury. Read each step of the instructions carefully. Make sure a proper understanding is achieved before proceeding.

Disassembly

NOTE: Refer to **Figures 2 - 4** for component identification on the following procedures.

Material Hoses from Meter

1. Unscrew Material Hose (1) from Electronic Meter (2).
2. Remove Capscrews (5), Lock Washers (15), and Nuts (16) that secure Pump Tube Assembly (4) to Cover (14).
 - Remove the Pump Tube Assembly from the Cover.
3. Unscrew the Electronic Meter from Nipple (3).
4. Remove Nozzle Assembly (22) from Material Hose (24) as required.
5. Unscrew both Material Hoses from Filter Assembly (23).

Nozzle (Non-Drip Manual)

NOTE: The Nozzle is serviced as an assembly only.

Fluid Filter **Figure 4**

6. Unscrew Spring and Adapter Assembly (43) from Body (39).
7. Remove O-Ring (42) from the Spring and Adapter Assembly.
8. Remove Stud (41) from the Body.
9. Remove Filter Tube (40) from the Body.

Lever and Cover from Pump Tube

10. Remove Capscrews (5), Lock Washers (15), and Nuts (16) that secure Pump Tube Assembly (4) to Cover (14).
 - Remove the Pump Tube Assembly from the Cover.
11. Remove Retaining Rings (6) from one end of Pin (7) and Pin (13).
12. Remove Pin (13) and Pin (7) from the Pump Tube Assembly.

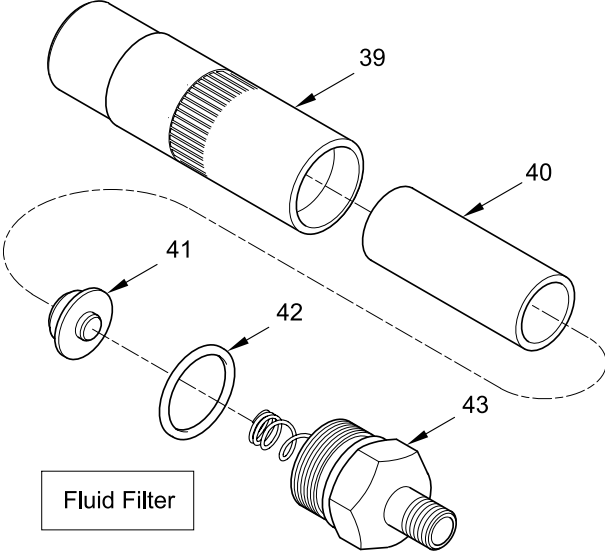

Item No.	Part No.	Description	Qty
39		Body	1
40	321191	Tube, Filter	1
41		Stud	1
42	171001-14	O-Ring, 3/4 " ID x 15/16 " OD	1
43		Spring and Adapter Assembly	1

Legend:
Part numbers left blank are not available separately

Figure 4 Fluid Filter Assembly 321203 - Exploded View

13. Remove Bracket and Lever Assembly (9) from the Pump Tube Assembly.
14. Remove Nut (12) from Screw (8).
15. Remove the Stud that secures Bracket and Lever Assembly (9) to Link (11).
16. Remove the Link from the Bracket and Lever Assembly.
17. Unscrew Knob (10) from the Bracket and Lever Assembly.
18. Remove Spring Clip (20) from Cover Assembly (14) as required.

Pump Tube

NOTE: Refer to **Figure 3** for component identification on the pump tube procedures.

19. Remove the Nipple from Outlet Body (28) as necessary.
20. Unscrew Tube (35) from the Outlet Body.
21. Remove the Tube from the inner components of the Pump Tube Assembly.

Foot Valve Body

22. Unscrew Foot Valve Body (37) from the Tube.
23. Remove Cotter Pin (38) from Foot Valve (36).
24. Remove the Foot Valve from the Foot Valve Body.

Outlet Body

25. Remove the Rod assembly from the Outlet Body.
26. Remove Gasket (34) from the Outlet Body.
27. Unscrew Packing Nut (25) from the Outlet Body.
 - Remove Gasket (27) and O-Ring (26).

Rod Assembly

28. Unscrew Nut (33) from Rod (29).
29. Remove Plunger Body (31) and Valve (30) from the Rod.
30. Remove O-Ring (32) from the Plunger Body.

Clean and Inspect

NOTE: Use the repair kit for replacement parts. Make sure all the components are included in the kit before discarding used parts.

1. Clean all metal parts in cleaning solvent. The solvent should be environmentally safe.
2. Inspect all parts for wear and/or damage.
 - Replace as necessary.
3. Inspect Rod (29) closely. Use a magnifying glass to detect any score marks.
 - Replace as necessary.
4. Closely inspect the mating surfaces of all check valve components for any imperfections. Ensure a smooth and clean contact is obtained when assembled.

Assembly

NOTE: Prior to assembly, certain components require lubrication in clean oil. Refer to **Table 2** for details.

Foot Valve Body

NOTE: Refer to **Figure 5** for a section view of the pump tube assembly.

1. Install Foot Valve (36) into the top of Foot Valve Body (37).
2. Install Cotter Pin (38) into the Foot Valve.
3. Screw the Foot Valve Body assembly into the bottom of Tube (35).
 - Do not tighten at this time.

Rod Assembly

4. Install Valve (30) and Plunger Body (31) [ribs upward] onto the bottom of Rod (29).
5. Screw Nut (33) onto the Rod.
 - Tighten the Nut securely.
6. Install O-Ring (32) onto the Plunger Body.

Item No. on Figure 3	Description
26	O-Ring, 1/2 " ID x 5/8 " OD
32	O-Ring, 1-1/4 " ID x 1-1/2 " OD

Table 2 Components Lubricated in Clean Oil

Outlet Body

7. Install and seat Gasket (34) into the bottom of Outlet Body (28).
8. Install the Rod assembly into the Outlet Body.
9. Install and seat Gasket (27) into the Outlet Body.
10. Install O-Ring (26) carefully past the cross-hole on the Rod.
11. Screw Packing Nut (25) into the Outlet Body.
12. Tighten the Packing Nut securely.
13. Install the Tube assembly over the Rod assembly and screw into the Outlet Body.
14. Tighten the Tube securely into the Outlet Body and at the same time the Foot Valve Body into the Tube.

Attach Pump Tube to Lever and Cover

15. Screw Knob (10) onto Bracket and Lever Assembly (9).
16. Install Link (11) into the Bracket and Lever Assembly.
17. Install Screw (8) that secures the Bracket and Lever Assembly to the Link.
18. Install Nut (12) onto the Screw.
 - Tighten the Nut securely.
19. Install the Bracket and Lever Assembly and Link onto the Pump Tube Assembly.
20. Install Pin (13) that secures the Link to the Pump Tube Assembly.
21. Install Pin (7) that secures the Bracket and Lever Assembly to the Pump Tube Assembly.
22. Install Retaining Rings (6) onto the ends of both Pins.
23. Screw Nipple (3) [with thread sealant on each end] into the Outlet Body.
 - Tighten the Nipple securely.
24. Screw Electronic Meter (2) onto the Nipple.
 - See **Figure 2** for the proper orientation of the Meter.
 - Tighten the Meter securely.
25. Position the Pump Tube Assembly onto Cover (14) as illustrated in **Figure 2**.

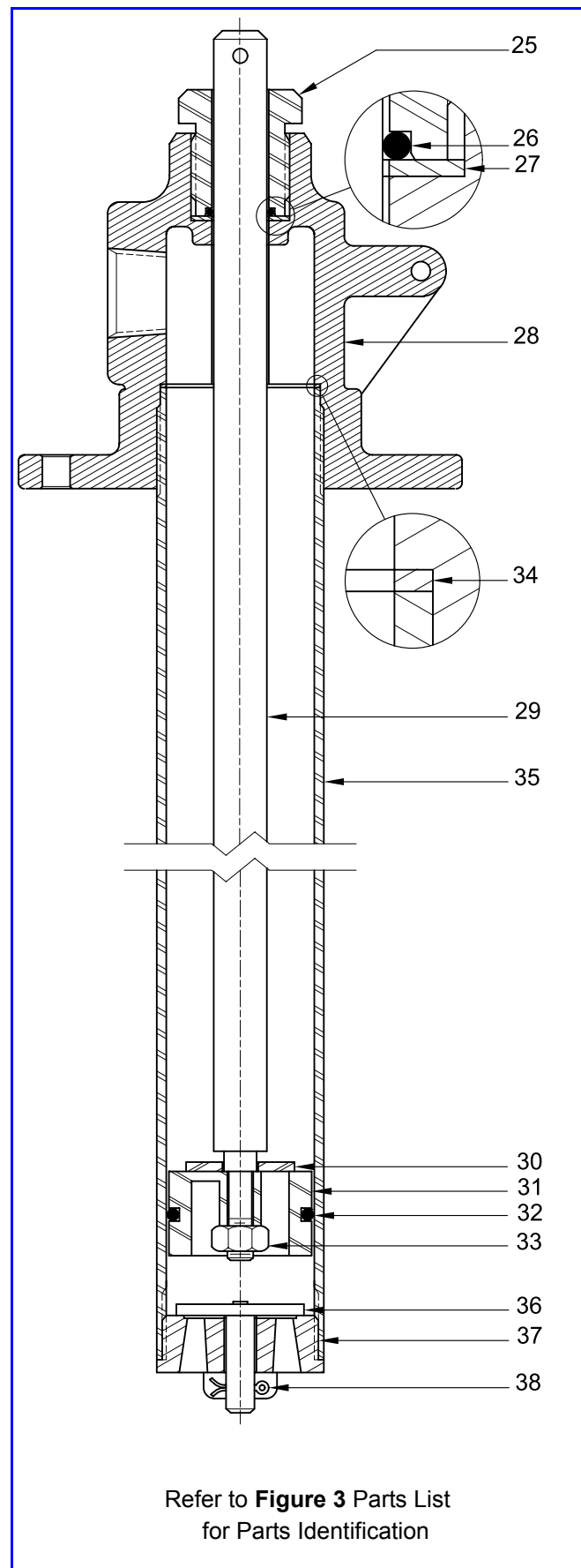

Refer to **Figure 3** Parts List
for Parts Identification

Figure 5 Pump Tube Assembly 328255-C4 - Section

26. Make sure Spring Clip (20) on the cover is properly oriented.
27. Install Nuts (16), Lock Washers (15), and Capscrews (5) that secure the Pump Tube Assembly to the Cover.
 - Tighten the Nuts securely.

Attach Material Hoses onto Meter

28. Screw Material Hose (1) [with thread sealant] into the Electronic Meter.
 - Tighten the Hose securely.
29. Screw Filter Assembly (23) [with thread sealant] onto the opposite end of the Material Hose.
30. Screw Material Hose (24) [with thread sealant] into the Filter Assembly.
 - Tighten the Hose securely.
31. Screw Nozzle Assembly (22) onto Material Hose (24) [with thread sealant] as required.

Fluid Filter

NOTE: Refer to **Figure 4** for component identification.

32. Install Filter Tube (40) into Body (39).
33. Install O-Ring (42) onto Spring and Adapter Assembly (43).
34. Install the small button of Stud (41) into the spring of the Spring and Adapter Assembly.
35. Screw the Spring and Adapter Assembly into the Body.
 - Tighten the Spring and Adapter Assembly securely.

Priming the Pump

1. Make sure an adequate supply of oil is in the container.
2. Position the Nozzle into a collection container.
3. Cycle the Lever until oil is visible at the Nozzle.

If the pump assembly does not prime, refer to the **Troubleshooting Chart** for details.

4. Continue to cycle the pump until the oil is free of air.
5. Reset the Electronic Meter to zero.

Troubleshooting Chart

Pump Indications	Possible Problems	Solution
Pump does not cycle	Pump tube jammed and/or contains loose components	Rebuild pump tube
Pump will not prime	Pump leaking internally	See Internal Leaks
Pump cycles easily	Product source empty	Replenish product
External Leaks		
Product leakage visible at Packing Nut (25)	1. Worn or damaged O-Ring (26) 2. Damaged Gasket (27)	1. Replace O-Ring (26) 2. Replace Gasket (27)
Product leakage at bottom of Outlet Body (28)	1. Tube (35) not sufficiently tight 2. Damaged Gasket (34)	1. Tighten Tube (35) into Outlet Body (28) 2. Separate Tube (35) from Outlet Body (28) and replace Gasket (34)
Internal Leaks		
Pump does not prime	1. Foreign material between Valve (30) and Plunger Body (31) 2. Foreign material between Foot Valve (36) and Foot Valve Body (37) 3. Worn or damaged Valve (30) 4. Worn or damaged Plunger Body (31) 5. Worn or damaged Foot Valve (36) 6. Worn or damaged Foot Valve Body (37) 7. Worn or damaged O-Ring (32)	Locate and eliminate source of foreign material Disassemble pump tube, clean, inspect, and replace worn or damaged components

Changes Since Last Printing
 Replaced Cotter Pins with Retaining Rings