

## Low-Pressure Transfer Pump

### Description

The major components of model 9616-S transfer pump consist of an air-operated motor and a pump tube. The air motor connects directly to the double-acting reciprocating pump tube.

This low-pressure (1:1 ratio) transfer pump is designed to deliver a range of light-weight oils including gear lubricants.

### Mounting

This pump mounts directly onto original containers or bulk tanks that have a 2 " NPTF bung fitting. The required length downtube screws directly into the 1-1/2 " NPTF female threads in the valve body.

As an alternative, the pump can also mount to a wall (with the use of a wall bracket) and be used with an optional suction hose. See **Table 2** for details.

Also, the pump screws directly onto two different size threaded standpipes [1-1/2 " NPTF (m) or 2 " NPTF (f)].

### Specifications

#### Air Motor

Piston Diameter x Stroke		Air Inlet	Max. Air Pressure	
Inches	Millimeters		psi	Bars
2-15/16 x 3	74.6 x 76.2	1/4 " NPTF (f)	150	10.3

For information on the air motor, refer to SER 338066-A1

#### Pump Tube

Max. Material Pressure		Delivery/Minute (Approximate)		Material Outlet	
psi	Bars	Gallons	Liters	w/Bushing	w/o Bushing
150	10.3	16	60.6	1/2 " NPTF (f)	3/4 " NPTF (f)

**Table 1** Model 9616-S Specifications

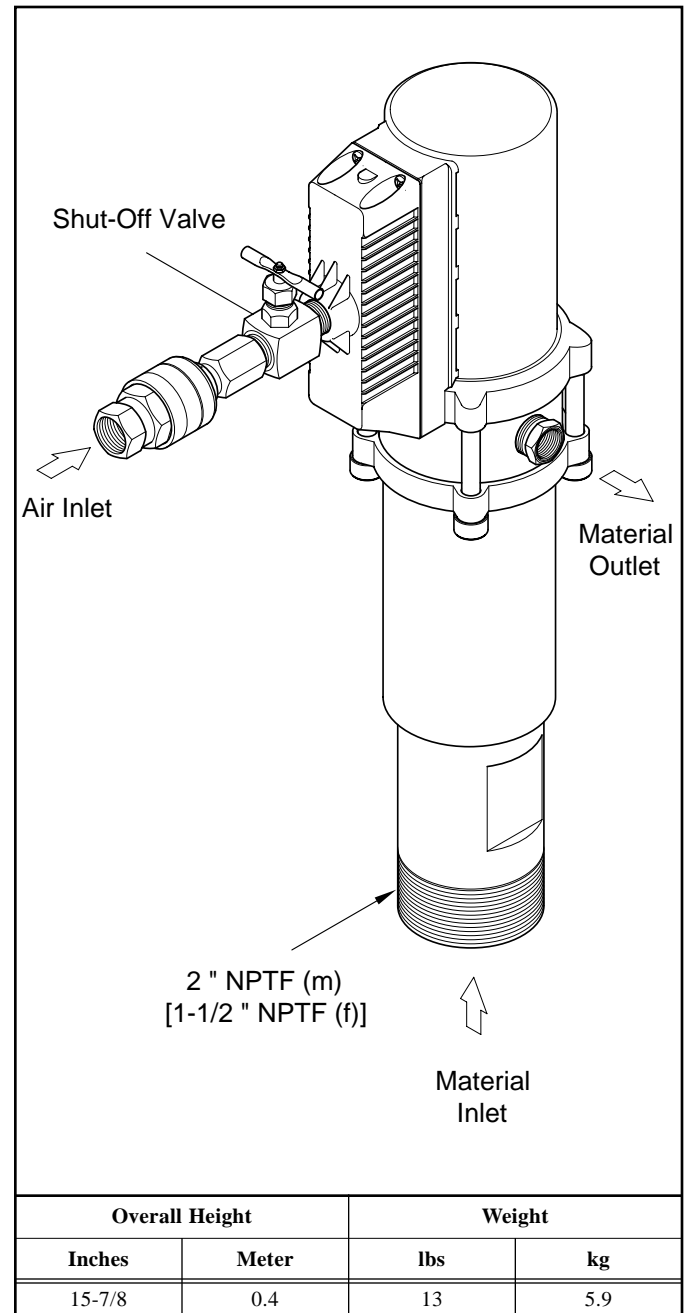

**Figure 1** Low-Pressure Transfer Pump Model 9616-S

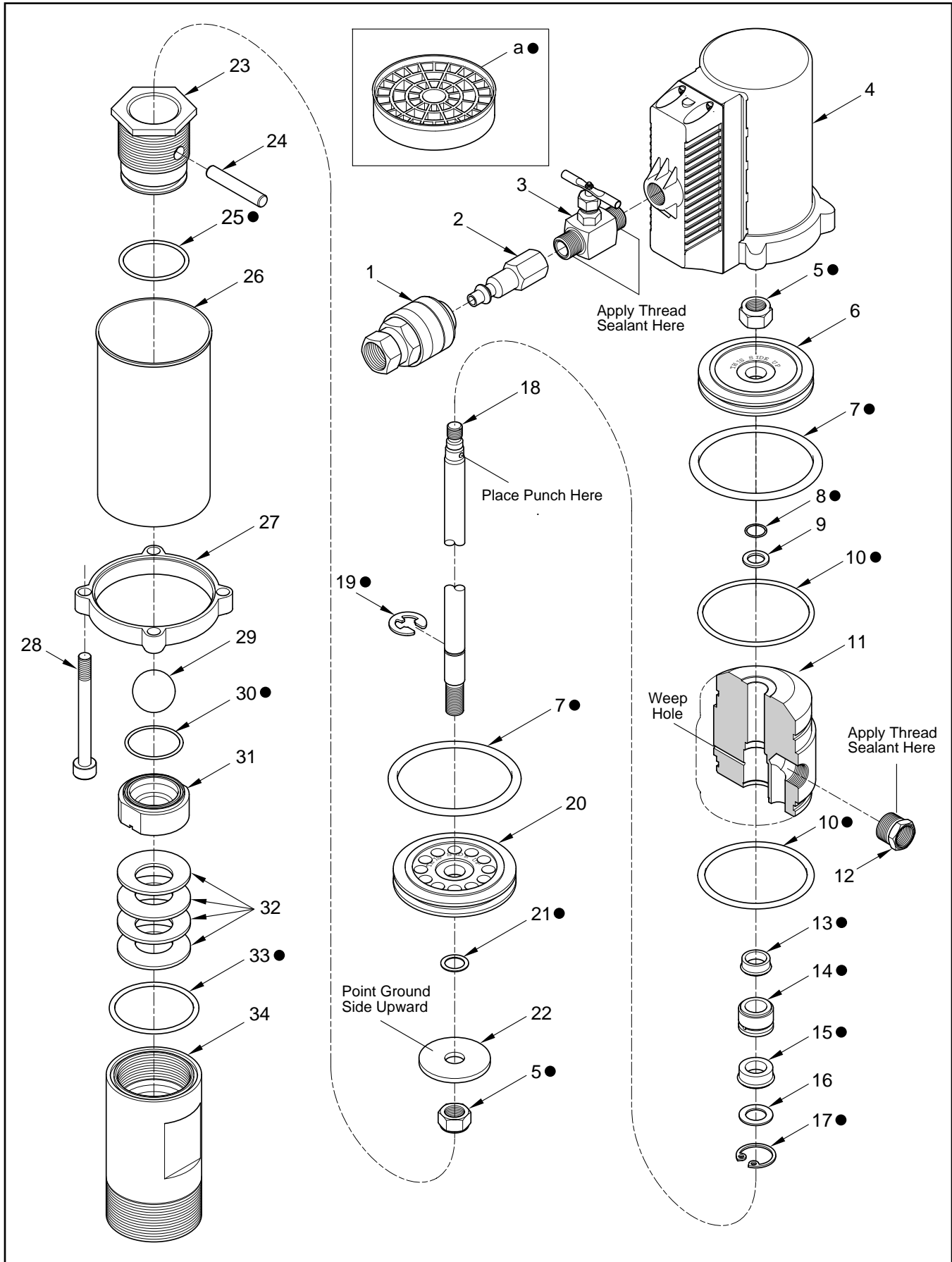

Figure 2 Low-Pressure Transfer Pump Model 9616-S - Exploded View

Item No.	Part No.	Description	Qty	Notes	Numeric Order Part # (Item #)
1	328030	Coupler, Air, 1/4 " NPTF (f)	1		51929 (5)
2	330605	Adapter, 1/4 " NPTF (f)	1		171000-7 (8)
3	319391	Valve, Shut-Off	1		171000-103 (7)
4		Motor Assembly, Air	1	See SER 338066-A1	171003-10 (10)
5	51929	Nut, Elastic Stop	2	●	171006-17 (17)
6	338111	Piston, Air	1		171009-14 (30)
7		O-Ring, 2-5/8 " ID x 3 " OD	2	●	171009-27 (25)
8	171000-7	O-Ring, 3/8 " ID x 1/2 " OD	1	●	171009-35 (33)
9	338109	Washer, 3/8 "	1		171016-50 (19)
10	171003-10	O-Ring, 2-3/4 " ID x 3 " OD	2	●	171700-56 (29)
11		Body, Outlet	1		172190-24 (13)
12	320531	Bushing, 3/4 " NPTF (m) x 1/2 " NPTF (f)	1		172190-26 (15)
13		Seal, 1/2 " ID x 3/4 " OD	1	●	319391 (3)
14	338072	Ring, Lantern (Brass)	1	●	320531 (12)
15		Seal, 1/2 " ID x 7/8 " OD	1	●	323474 (16)
16	323474	Washer	1		328030 (1)
17		Ring, Retaining, Internal	1	●	330605 (2)
18	338589	Rod	1		338066-A1 (4)
19		Ring, Retaining, External	1	●	338072 (14)
20		Piston, Fluid	1		338109 (9)
21		Gasket (Aluminum)	1	●	338111 (6)
22	338259	Plate (Stainless Steel)	1		338259 (22)
23	338591	Stop	1		338261 (26)
24	338590	Pin, 1/4 " Dia. x 1-5/8 " Long	1		338271 (a)
25		O-Ring, 1-7/16 " ID x 1-5/8 " OD	1	●	338272 (21)
26	338261	Cylinder	1		338283 (27)
27	338283	Ring	1		338588 (11)
28	338594	Screw, 5/16 " -18 x 2-1/2 "	4		338589 (18)
29	171700-56	Ball	1		338590 (24)
30		O-Ring, 1-1/4 " ID x 1-3/8 " OD	1	●	338591 (23)
31	338592	Seat	1		338592 (31)
32	338595	Spring, Disc	4		338593 (34)
33	171009-35	O-Ring, 1-15/16 " ID x 2-1/8 " OD	1	●	338594 (28)
34	338593	Body, Valve	1		338595 (32)
<b>Kit Component for Model 9616-A</b>					339384 (20)
a	338271	Piston (Nylon)	1	●	

**Legend:**

Part numbers left blank (or in *italics*) are not available separately  
 ● designates a repair kit item

**Repair Kits**

Part No.	Kit Symbol	Description
<b>393627</b>	●	Kit, Major Repair (Includes tube of 393590 Teflon Grease)
393530-24		Kit, Seal [includes five (5) of item number 13]
393530-26		Kit, Seal [includes five (5) of item number 15]

## Accessories

This model pump can be used in a variety of locations which allows an assortment of accessory items to be utilized. Please refer to the Sales Catalog for details on additional accessory items.

Description	Part Number
Low Level Cut-Off Valve	321206
Siphon Kit	SWA 306
Wall Bracket	325749
Metal Discharge Hose (4-Feet)	338360

**Table 2** *Model 9616-S Accessory Components*

## Preventive Maintenance

Refer to section entitled **Overhaul** for the procedures necessary to perform maintenance.

Daily	Weekly	Monthly	Yearly
Wipe Exterior with Clean Cloth	Inspect for Air and/or Material Leakage		

**Table 3** *9616-S Model Series Preventive Maintenance Schedule*

## Overhaul

**NOTE:** Refer to **Figure 2** for component identification on all overhaul procedures.

Prior to performing any maintenance procedure, the following safety precautions must be observed. Personal injury may occur.



### WARNING

**Do not use halogenated hydrocarbon solvents such as methylene chloride or 1,1,1 trichloroethane in this pump. An explosion can result within an enclosed device capable of containing pressure when aluminum and/or zinc-plated parts in the pump come in contact with halogenated hydrocarbon solvents.**

**Release all pressure within the system prior to performing any overhaul procedure.**

- **Disconnect the air supply line from the pump motor.**
- **Into an appropriate container, operate the control valve to discharge remaining pressure within the system.**

**Never point a control valve at any portion of your body or another person. Accidental discharge of pressure and/or material can result in injury.**

**Read each step of the instructions carefully. Make sure a proper understanding is achieved before proceeding.**

## Disassembly

### Separate Air Motor from Pump Tube

1. Clamp the pump assembly in a soft-jaw vise.
2. Remove Capscrews (28) that secure Ring (27), Cylinder (26), and Air Motor Assembly (4) to Outlet Body (11).
  - Remove the Ring from the Cylinder.
3. With a side-to-side motion, pull the Air Motor Assembly from the Outlet Body.
  - Lubricate upper O-Ring (10) with oil to ease separation.

**NOTE:** The following three (3) steps are performed only as required.

4. Remove Coupler (1) from Adapter (2).

5. Unscrew the Adapter from Shut-Off Valve (3).

6. Unscrew the Shut-Off Valve from the Air Motor Assembly.

### Pump Tube Assembly

7. With a side-to-side motion, pull the Cylinder assembly from the Outlet Body.
  - Lubricate lower O-Ring (10) with oil to ease separation.
8. Unscrew Bushing (12) from the Outlet Body as required.
9. Remove O-Rings (10) from the Outlet Body.
10. Remove O-Rings (7) from Air Piston (6) and Fluid Piston (20).
11. Unscrew Valve Body (34) from Stop (23).
  - Use a 2-inch socket to secure the Stop.
12. Remove O-Ring (33) from the Valve Body.
13. Remove O-Ring (25) from the Stop.
14. Remove Pin (24) from the Stop as required.
15. Remove Ball (29), Seat (31), and Spring Discs (32) from the Valve Body.
16. Remove O-Ring (30) from the Seat.
17. Remove upper Nut (5) that secures Air Piston (6) to Rod (18).
  - Remove the Air Piston from the Rod.

**NOTE:** Place an appropriate size punch or other suitable tool into the hole of the Rod. See **Figure 2**.

18. Remove O-Ring (8) and Washer (9) from the Upper Rod.
19. Remove the Rod (with attached components) from the Outlet Body.
20. Remove lower Nut (5) that secures Fluid Piston (20) to the Rod.
  - **NOTE:** Place an appropriate size punch or other suitable tool into the hole of the Rod.
21. Remove Plate (22), Gasket (21), and the Fluid Piston from the Rod.
22. Remove Retaining Ring (19) from the Rod as needed.
23. Remove Retaining Ring (17), Washer (16), Seal (15), Lantern Ring (14), and Seal (13) from the Outlet Body.

## Clean and Inspect

1. Clean all metal parts in cleaning solvent. The solvent should be environmentally safe.
2. Inspect all parts for wear and/or damage.
  - Replace as necessary.
3. Inspect Air Piston (6) and Fluid Piston (20) for fatigue cracks.
  - Replace as necessary.
4. Inspect Rod (18) closely. Use a magnifying glass to detect any score marks on the Rod.
  - Replace as necessary.
5. Closely inspect the mating surfaces of all check valve components for any imperfections. Ensure a smooth and clean contact is obtained when assembled.

**EXAMPLE:** Place Ball (29) into Seat (31). Fill the Seat with solvent. Make sure no leakage occurs.

## Assembly

**NOTE:** Prior to assembly, certain components require lubrication. Refer to **Table 4** for details.

### Pump Tube Assembly

**NOTE:** Refer to **Figure 3** for a section view of the pump tube assembly.

### Outlet Body

1. Install and seat Seal (13) [stem end first], Lantern Ring (14) [stepped end first], Seal (15) [stem end first], and Washer (16) into Outlet Body (11).
2. Secure the components with Retaining Ring (17).
  - Make sure the Retaining Ring seats properly in the groove.

3. Install O-Rings (10) onto both ends of the Outlet Body.
4. Install Retaining Ring (19) onto Rod (18).

*IMPORTANT: Make sure the ground side of Plate (22) contacts Fluid Piston (20).*

5. Install Fluid Piston (20) (observe THIS SIDE UP), Gasket (21), and Plate (22) [ground side first] onto the bottom of the Rod.
6. Install Nut (5) that secures the Plate to the Rod.
  - Tighten the Nut securely.
  - Place an appropriate size punch or other suitable tool into the hole of the Rod.

## CAUTION

**Install the Rod assembly into the Body with a twisting motion. Use care not to damage the Seals.**

7. Install the Rod assembly into the bottom of the Outlet Body.
  - Position the Fluid Piston flush with the bottom of the Body.
8. Install Washer (9), O-Ring (8), and Air Piston (6) (observe THIS SIDE UP) onto the Rod.
9. Install Nut (5) that secures the Air Piston to the Rod.
  - Tighten the Nut securely.
  - Place an appropriate size punch or other suitable tool into the hole of the Rod.
10. Install O-Rings (7) onto each Piston.
11. Screw Stop (23) into Cylinder (26) until it seats.
12. Install Pin (24) into the Stop.
  - Make sure the Pin does not protrude from either side of the Stop.

Item No.	Description	Notes	Item No.	Description	Notes
<b>Clean Oil</b>					
10	O-Ring, 2-3/4 " ID x 3 " OD (Lower)	Pump Tube Portion	25	O-Ring, 1-7/16 " ID x 1-5/8 " OD	
13	Seal, 1/2 " ID x 3/4 " OD		30	O-Ring, 1-1/4 " ID x 1-3/8 " OD	
15	Seal, 1/2 " ID x 7/8 " OD		33	O-Ring, 1-15/16 " ID x 2-1/8 " OD	
<b>Magnalube-G Teflon Grease</b>					
7	O-Ring, 2-5/8 " ID x 3 " OD (Upper)	For Air Piston (6)	10	O-Ring, 2-3/4 " ID x 3 " OD (Upper)	Air Motor Portion
8	O-Ring, 3/8 " ID x 1/2 " OD				
Coat the Inside Diameter of the Air Motor Assembly					

**Table 4 Lubricated Components**

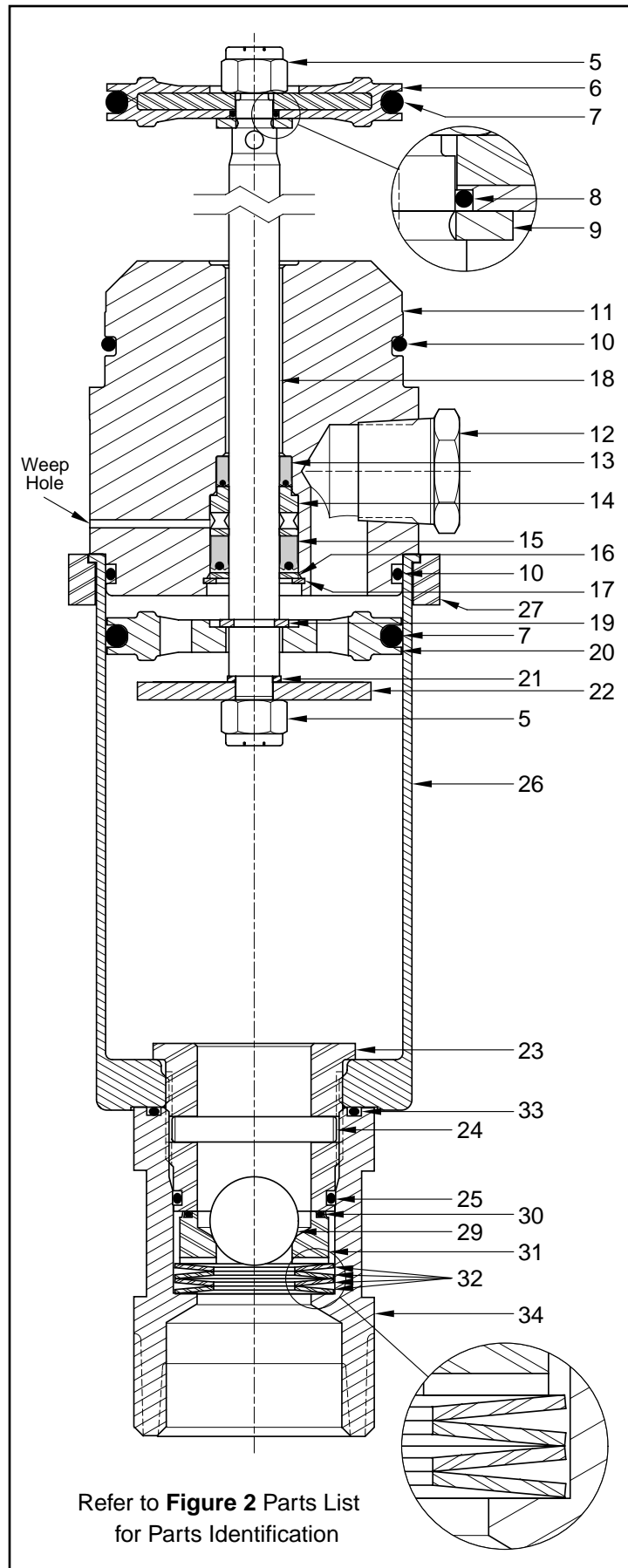

Refer to **Figure 2** Parts List  
for Parts Identification

13. Install O-Ring (25) onto the Stop.
  14. Install and seat Spring Discs (32) in an alternate pattern into Valve Body (34).
    - See **Figure 3** for details.

*IMPORTANT: Make sure to press O-Ring (30) fully into the groove of Seat (31).*
  15. Install and seat O-Ring (30) into Seat (31).
  16. Install the Seat assembly [O-Ring upward] into the Valve Body.
  17. Install Ball (29) into the Seat.
  18. Install and seat O-Ring (33) onto the groove of the valve Body.
  19. Screw the Valve Body assembly onto the Stop.
    - Tighten the Valve Body securely.
  20. Install Air Motor Assembly (4) squarely onto the Body.
    - Use care passing the O-Ring.
    - Make sure the outlet of the Body orients properly with the inlet of the Air Motor.
  21. Install the Cylinder assembly squarely onto the bottom of the Outlet Body.
    - Use care passing the O-Ring.
  22. Install and seat Ring (27) [counter bore end first] onto the Cylinder.
    - Rotate the Ring until the holes align with the Air Motor Assembly.
  23. Install Screws (28) that secure the Ring to the Air Motor Assembly.
    - Tighten the Screws evenly and securely in a crisscross pattern.
  24. Screw Bushing (12) [with thread sealant] into the Outlet Body.
    - Tighten the Bushing securely.
- Air Motor Assembly**
25. Screw Shut-Off Valve (3) [with thread sealant] into the Air Motor Assembly.
    - Tighten the Shut-Off Valve securely in the position required.
  26. Screw Adapter (2) onto the Shut-Off Valve [with thread sealant].
    - Tighten the Adapter securely.
  27. Install Air Coupler (1) onto the Adapter.

**Figure 3** Pump Tube Assembly - Section View

## Operation



### WARNING

**Do not exceed the lowest pressure rating of any component in the system.**

**Never point a control valve at any portion of your body or another person. Lubricant discharged at high velocity can penetrate the skin and cause severe injury. Should any fluid appear to puncture the skin, get medical care immediately.**

**Ensure all components are in operable condition. Replace any suspect parts prior to operation. Personal injury can occur.**

1. Make sure air pressure at the regulator reads zero.
2. Slowly supply air pressure [not to exceed 20 psi (1.4 Bars)] to the pump's motor.
  - The pump assembly should cycle.

If the pump assembly does not cycle, refer to the **Troubleshooting Chart** for details.

With air pressure at zero:

3. Connect a product hose to the pump's material outlet.
  - Direct the hose into an appropriate container.
4. Place the pump in the product to be dispensed.
5. Slowly supply air pressure to the pump's motor.
6. Allow the pump to cycle slowly until the system and product is free of air.

If the pump assembly does not prime, refer to the **Troubleshooting Chart** for details.



### WARNING

**Should leakage occur anywhere within the system, disconnect air to the motor. Personal injury can occur.**

With air pressure at zero:

7. Attach a control valve to the outlet hose of the pump.
8. Slowly supply 35 psi (2.4 Bars) air pressure to the pump's motor.
9. Operate the control valve into a container.

10. Allow the pump to cycle until the system and product is once again free of air.
11. Shut off the control valve.
12. Set the air pressure to 100 psi (6.9 Bar).
13. Visually inspect the pump for external leaks.
  - The pump should not cycle.

If the pump does not stall, refer to the **Troubleshooting Chart** for details.

14. Check the motor for air leakage.

If the motor leaks, refer to the **Troubleshooting Chart** in the **Air Motor Service Guide** for details.

## Installation

Additional items that should be incorporated into the air piping systems are listed in **Table 5**.

Part Number	Description
5604-2	Moisture Separator
7604-B	Regulator and Gauge

**Table 5** *Air Line Components*

## Troubleshooting Chart

Pump Indications	Possible Problems	Solution
Pump does not cycle	<ol style="list-style-type: none"> <li>1. Air motor not operating properly</li> <li>2. Pump tube jammed and/or contains loose components</li> <li>3. Insufficient air pressure</li> </ol>	<ol style="list-style-type: none"> <li>1. Inspect air motor and rebuild or replace as necessary</li> <li>2. Rebuild pump tube</li> <li>3. Increase air pressure</li> </ol>
Pump will not prime	<ol style="list-style-type: none"> <li>1. Excessive cycling speed</li> <li>2. Pump leaking internally</li> </ol>	<ol style="list-style-type: none"> <li>1. Reduce air pressure</li> <li>2. See <b>Internal Leaks</b></li> </ol>
Pump cycles rapidly	<ol style="list-style-type: none"> <li>1. Product source empty</li> </ol>	<ol style="list-style-type: none"> <li>1. Replenish product</li> </ol>
Pump will not stall (cycles more than once or twice per hour)	<ol style="list-style-type: none"> <li>1. Pump requires break-in period</li> <li>2. Pump leaking internally</li> <li>3. Pump leaking externally</li> <li>4. Distribution system leaking</li> </ol>	<ol style="list-style-type: none"> <li>1. Operate the pump against moderate fluid pressure for up to one hour</li> <li>2. See <b>Internal Leaks</b></li> <li>3. See <b>External Leaks</b></li> <li>4. Correct leak</li> </ol>
<b>External Leaks</b>		
Product leakage visible at weep hole in Outlet Body (11)	<ol style="list-style-type: none"> <li>1. Damaged Seal (15)</li> <li>2. Damaged Rod (18)</li> </ol>	<ol style="list-style-type: none"> <li>1. Replace Seal (15)</li> <li>2. Inspect Rod (18) and replace as necessary</li> </ol>
Product leakage visible at bottom of Outlet Body (11)	<ol style="list-style-type: none"> <li>1. Screws (28) not sufficiently tight</li> <li>2. Damaged O-Ring (10)</li> </ol>	<ol style="list-style-type: none"> <li>1. Tighten Screws (28) into Air Motor Assembly (4)</li> <li>2. Separate Cylinder (26) from Outlet Body (11) and replace O-Ring (10)</li> </ol>
Air leakage at weep hole in Outlet Body (11)	Damaged Seal (13)	Replace Seal (13)
Product leakage visible between Cylinder (26) and Valve Body (34)	<ol style="list-style-type: none"> <li>1. Stop (23) not sufficiently tight into Valve Body (34)</li> <li>2. Damaged O-Ring (24)</li> </ol>	<ol style="list-style-type: none"> <li>1. Tighten Stop (23) into Valve Body (34)</li> <li>2. Separate Valve Body (34) from Stop (23) and replace O-Ring (24)</li> </ol>
<b>Internal Leaks</b>		
Pump does not prime or cycles continuously, or slowly (once or twice/hour)	<ol style="list-style-type: none"> <li>1. Foreign material between Ball (29) and Seat (31)</li> <li>2. Foreign material between Plate (22) and Fluid Piston (20)</li> <li>3. Worn or damaged Ball (29)</li> <li>4. Worn or damaged Seat (31)</li> <li>5. Worn or damaged O-Ring (7)</li> <li>6. Worn or damaged Cylinder (26)</li> <li>7. Worn or damaged Plate (22)</li> <li>8. Worn or damaged Fluid Piston (20)</li> </ol>	<p>Locate and eliminate source of foreign material.</p> <p>Disassemble pump tube, clean, inspect, and replace worn or damaged components</p>

**Changes Since Last Printing**

Initial Release

