

High-Pressure Pump (Stationary and Portable)

Description

The major components of the high-pressure pump assembly in the 9950-A1 and 9951-1 model series consist of a(n):

- air-operated motor
- double-acting reciprocating pump tube
- cover assembly
- follower plate
- control valve, z-swivel, and hose (Model 9951-1 series)
- dolly ((Model 9951-1)
- two-wheel hand truck (Model 9951-T1)

Pump Assembly

The high-pressure (50:1 ratio) pump included with the assembly is designed to deliver a range of greases [up to NLGI # 3] and operate directly from their original 120-pound container.

Models 9950-A1 and 9951-1 Series

Each model in the 9951-1 series includes a control valve, z-swivel, and delivery hose.

Portable

Model 9951-1 also includes a dolly while model 9951-T1 is equipped with a hand truck.

Stationary

Model 9950-A1 is stationary. See **Figure 1**.

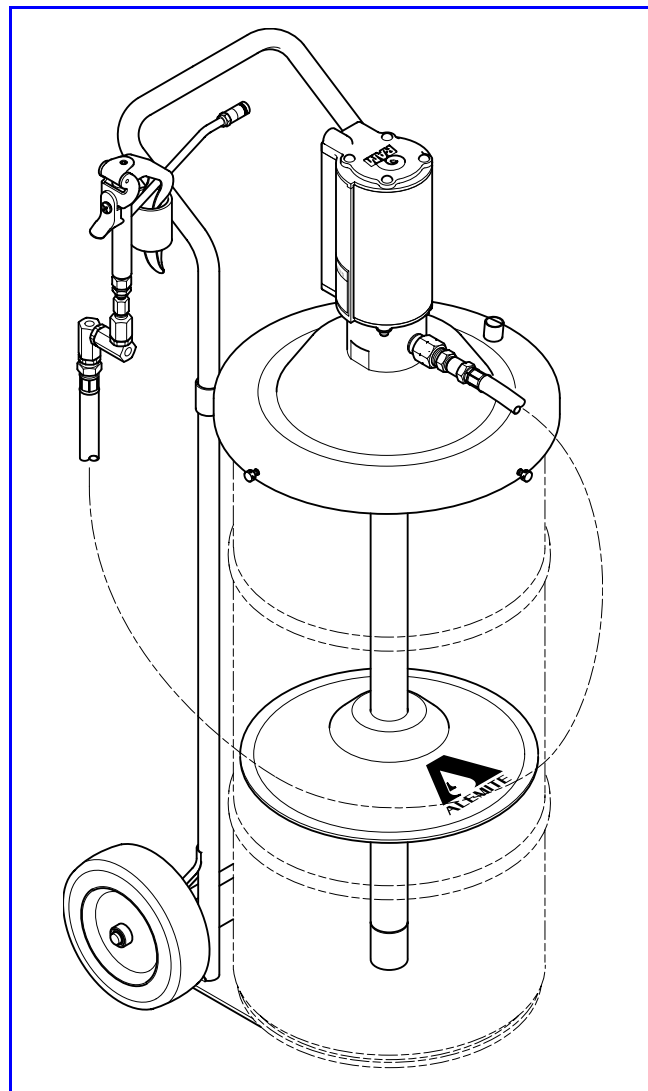

Specifications

IMPORTANT: For detailed information on the pump tube (including specifications and performance data) refer to SER 9911-1/9950-1.

For information on the motor, please refer to SER 339413.

Pump Model	Control Valve, Swivel & Hose	Dolly	Hand Truck	Width x Height (including container)	
				Inches	Cm
9950-A1				15 x 36-1/2	38.1 x 92.7
9951-1	●	●		20-1/4 x 39	51.4 x 99.1
9951-S1	●			15 x 36-1/2	38.1 x 92.7
9951-T1	●		●	15 x 38	38.1 x 96.5

Figure 1 High-Pressure Pump
 Models 9950-A1 and 9951-1 Series - Model 9951-T1 Shown

Item No.	Part No.	Description	Qty	Pump Model				Notes	Numeric Order Part # (Item #)
				9950-A1	9951-I	9951-S1	9951-T1		
1	9950-1	Pump Assembly, High-Pressure	1		All			See SER 9911-1/9950-1	1001-66
2	44734	Adapter, 1/2 " -27 x 3/8 " NPTF (m)	1	●	●	●	●		6320-3 (15)
3	315669	Adapter, 3/8 "NPTF (m)	1	●					9950-1 (1)
4	317875-7	Hose Assembly, Material	1	●	●	●	●		17804 (8)
5	315943	Bushing	1	●	●	●	●		44734 (2)
6	338371	Cover Assembly	1					Includes items 10-13	48018 (7)
7	48018	Screw, Thumb, 1/4 " -28 x 1-1/8 "	3						B52752 (14)
8		Washer, 1/4 "	3						77009 (16)
9		Washer, Lock, 1/4 "	3						77786 (10)
10		Capscrew, 1/4 " -20 x 1/2 "	3						170561 (17)
11	338802	Plate, Follower	1						172207-1 (9)
12	316315-5	Dolly Assembly	1	●				See SER 316315-5	315669 (3)
13	338958	Truck, Hand, Two-Wheel	1				●		315943 (5)
14	52752	Z-Swivel Assembly, High-Pressure	1	●	●	●	●	See SER B52750	316315-5 (12)
15	6320-3	Valve Assembly, Control	1	●	●	●	●	See SER 6320-3	317875-7 (4)
16		Washer, Internal Tooth Lock, 1/4 "	1	●	●	●	●		338371 (6)
17		Screw, 1/4 " -20 x 5/16 "	1	●	●	●	●		338802 (11)
	1001-66	Adapter, Union, 90 °, 3/8 " NPTF	1	●				Not Illustrated	338958 (13)

Legend:

Part numbers left blank (or in *italics*) are not available separately

Assembly

NOTE: Refer to **Figure 2** for component identification on all assembly procedures.

CAUTION

Select a clean environment for all assembly procedures. Prevent contamination from foreign material. Damage to components can occur.

Pump Assembly

IMPORTANT: Make sure to remove the protective cover from the inlet of Pump Assembly (1).

1. Install Pump Assembly (1) into Cover (6).
2. Secure the Pump Assembly to the Cover with Washers (8), Lock Washers (9), and Capscrews (10).
 - Tighten the Capscrews securely.

IMPORTANT: Do not apply thread sealant to the first two (2) threads of any connection. Contamination can occur.

Cover Assembly and Follower Plate

3. Place Follower Plate (11) onto the top of the product.
 - With a wobbling motion, eliminate any air that may be trapped underneath the Follower Plate. Force the product through the hole in the center of the Plate.

NOTE: On model 9951-T1, place the container on Hand Truck (13). Slide each hook onto the lip of the container.

On model 9951-1, secure the container to Dolly (12). Refer to SER 316315-5 for details.

4. Guide the pump tube into the Follower Plate and fit the Cover onto the container.
5. Secure the Cover to the container with Thumb Screws (7).
6. Screw the large diameter end of Adapter (2) [with thread sealant] into the outlet of the Pump Assembly.
 - Tighten securely.

NOTE: On model 9950-A1, screw Adapter (3) [with thread sealant] into the outlet of the Pump Assembly and tighten securely.

Control Valve and Material Hose

NOTE: The following procedures are applicable to model 9951-1 series pumps.

7. Screw either end of Material Hose (4) into Adapter (3).
 - Tighten securely.
8. Screw the 1/2 " -27 end of Z-Swivel (14) [with thread sealant] into the Material Hose.
 - Tighten securely.
9. Screw the opposite end of the Z-Swivel [with thread sealant] into Control Valve (15).
 - Tighten securely.
10. Test/Prime the Pump assembly.
 - Refer to Service Guide SER 9911-1/9950-1 for details.

Adapter for Model 9950-A1

The 1001-66 Union Adapter (not illustrated) is used to attach the lubricant connecting hose [not included] to the system's piping.

Changes Since Last Printing

Initial Release